

LED driver IC



***MV1012SC***







**Application Note**  
**Version 1.1**

## Precautions

Thank you for purchasing this product.

When using this IC, please follow the warnings and cautions given below to ensure safety.

Warning		Improper handling may result in death, serious injury, or major property damage.
Caution		Improper handling may result in minor injury or property damage.

Warning		This IC is intended to be used for general electronic equipment (office equipment, communication equipment, measurement equipment, consumer electronics, etc.). Do not use the product for medical equipment, aerospace planes, trains, transportation equipment (vehicles, ships, etc.), or nuclear power control systems that may directly affect human life or health in case of a malfunction or trouble. Contact us before using the product in applications other than general electronic equipment.
Caution		Never attempt to repair or modify the product. Doing so may lead to serious accidents. <<Electric shock, destruction of property, fire, or malfunctions may result.>>
		In the event of a problem, an excessive voltage may arise at an output terminal, or the voltage may drop. Anticipate these fluctuations and any consequential malfunctions or destruction and provide adequate protection for equipment, such as overvoltage or overcurrent protection.
		Check the polarity of the input and output terminals. Make sure they are properly connected before turning on power. <<Failure to do so may lead to failure of the protective element or generate smoke or fire.>>
		Use only the specified input voltage. Deploy a protective element on the input line. <<Problems may result in smoke or fire.>>
		In the event of a malfunction or other anomaly, shut power off and contact us immediately.

- The contents of this document are subject to change without notice.
- Use of this product constitutes acceptance of the formal specifications.
- We have taken every possible measure to ensure the accuracy of the information in this document. However, we will not be held liable for any losses or damages incurred or infringements of patents or other rights resulting from use of this information.
- This document does not guarantee or license the execution of patent rights, intellectual property rights or any other rights of Shindengen or third parties.
- No part of this document may be reproduced in any form without prior consent from Shindengen.

 Although we continuously make every effort to enhance the quality and reliability of our products, there is a certain probability of failure or malfunction in semiconductor products. It is advisable for customers to consider taking any safety measures in their design, such as redundancy, fire containment, and malfunction prevention to avoid personal injury, fires, or social damages.

 Our semiconductor products contained in this manual require especially high grade of quality and reliability and are not designed and manufactured to be used in equipment or systems of which failures or malfunctions may directly affect human life or health. When using the product in special or specific applications described below, be sure to contact us to confirm whether the intended use of the product is appropriate.

### Special applications

Transportation equipment (vehicles, ships, etc.), trunk-line communication equipment, traffic signal control systems, disaster/crime prevent systems, various safety equipment, medical equipment, etc.

### Specific applications

Nuclear power control systems, aircraft equipment, aerospace equipment, submarine repeaters, life-support systems, etc.

 Not only for the above special and specific applications, when you use our IC products also for equipment and systems that are intended for continuous operation and expected to last for a long time, please contact us.

**We provide support for circuit design to ensure safe use of our IC products. Please contact our sales representative or product marketing department if you have any questions.**

## Contents

1. Overview.....	4
1.1 Features.....	4
1.2 Block diagram .....	4
1.3 Pin assignment .....	5
1.4 Pin functions .....	5
2. Explanation of basic operations.....	6
2.1 Starting sequence.....	7
3. Component selection procedure and calculation method.....	8
3.1 Basic circuit configuration .....	8
3.2 Component selection .....	9
3.2.1 MOSFET (Q1) .....	9
3.2.2 Fly-wheel diode (D1) .....	10
3.2.3 Current detection resistor (R1 and R2).....	10
3.2.4 Inductor (L1).....	11
3.2.5 Gate drive circuit (R4, R9, and D2).....	11
3.2.6 Resistors for Svin and Svout pins(R5, R6, R7 and R8).....	12
3.2.7 CS pin filter (R3 and C4) .....	12
3.2.8 Vcc pin smoothing capacitor (C3).....	13
3.2.9 REF pin capacitor (C5).....	13
3.2.10 Svin pin capacitor (C9).....	13
3.2.11 Resonant capacitor (Cr) .....	13
3.2.12 Input capacitor (C1) and Output capacitor (C2).....	13
3.2.13 Svout pin capacitor (C8).....	13-14
3.3 Winding voltage supply.....	15
3.3.1 Configuration of a winding voltage supply .....	15
3.3.2 Selecting the auxiliary winding (Nc).....	15
3.3.3 Selecting the auxiliary winding rectifier diode (D3).....	15
3.3.4 LED open-circuit protection using auxiliary winding.....	16
4. Cautions on pattern designing.....	17
4.1 Cautions.....	17
4.2 PCB pattern example.....	18

5. Dimming characteristics.....	19
5.1 Operation in each mode.....	20
5.1.1 [A] Frequency modulation region.....	20
5.1.2 [B] Off-time modulation region.....	21-22
5.1.3 [C] Oscillation off region .....	23
5.2 PWM dimming.....	24
5.2.1 PWM dimming in 100% and Oscillation off regions .....	24
5.2.2 Combination of linear dimming and PWM dimming.....	25
5.3 Dimming circuit .....	26
5.3.1 Example of dimming circuit smoothing PWM signal .....	26
6. Operations in abnormal situations .....	27
6.1 LED open-circuit .....	27
6.2 LED short-circuit .....	27
6.3 Abnormal heat buildup .....	28
6.4 CS pin open-circuit.....	28
6.5 CS-GND short-circuit .....	28
6.6 Current detection resistor open-circuit .....	28
6.7 Current detection resistor short-circuit .....	28
7. Standard circuit example .....	29
7.1 Power supply specification and circuit diagram.....	29
7.2 Power supply characteristics.....	30
7.3 Example of operation waveform.....	30-31

## 1. Overview

### 1.1 Features

The MV1012SC is an LED driver IC that uses an external power supply and can consist solely of low-voltage pins. Omitting the auxiliary winding enables a single power supply configuration, and quasi-resonant operation in critical conduction mode raises efficiency and lowers noise.

In general critical conduction mode, the switching frequency increases when the dimming ratio decreases. This increases switching losses and imposes limitations on the lowest dimming ratios, disadvantageously. When the dimming ratio decreases, the MV1012SC automatically switches from critical conduction mode to discontinuous conduction mode. This prevents the switching frequency increasing, reduces switching losses, and achieves smooth and deep dimming free of flickering. The MV1012SC can stop gate output by holding the  $V_{REF}$  at or below the oscillation-off REF pin threshold voltage ( $V_{th\_REF\_sp}$ ).

The MV1012SC has the following features:

- Allows quasi-resonant operation without auxiliary winding.
- Quasi-resonant operation in critical conduction mode helps achieve low input change, raises efficiency, and lowers noise.
- Off-time modulation enables deep dimming (1% or less).
- Allows PWM dimming input and linear dimming input.
- Gate output stop at  $V_{REF} \leq V_{th\_REF\_sp}$ .
- Allows LED open-circuit protection using auxiliary winding.
- Features UVLO, and LED short-circuit protection.
- Allows configuration solely of low voltage pins using an external start-up circuit.

### 1.2 Block diagram

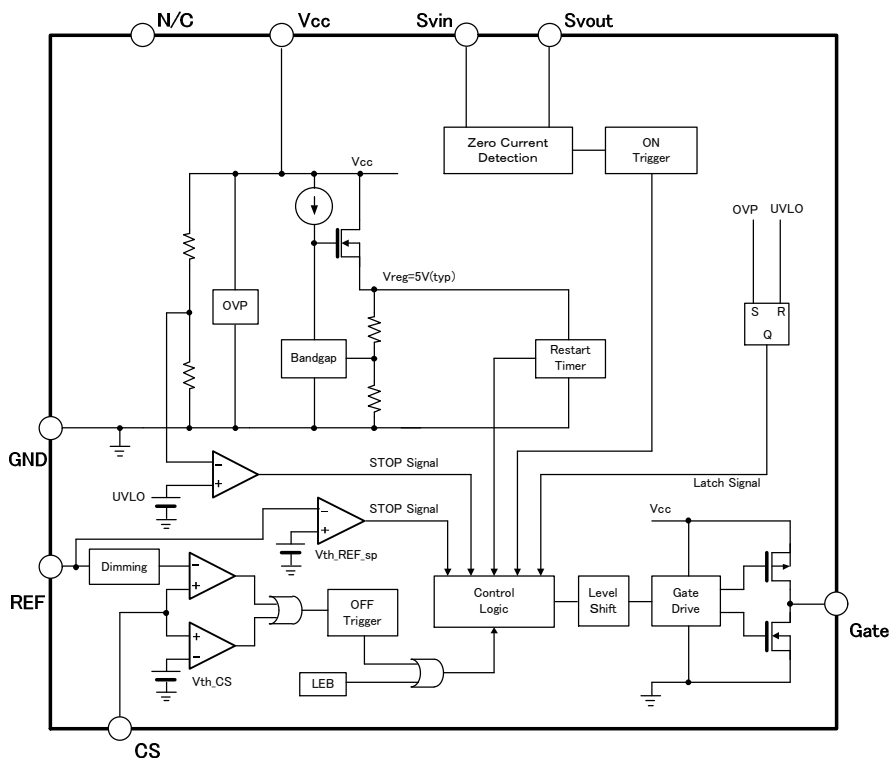

## 1.3 Pin assignment

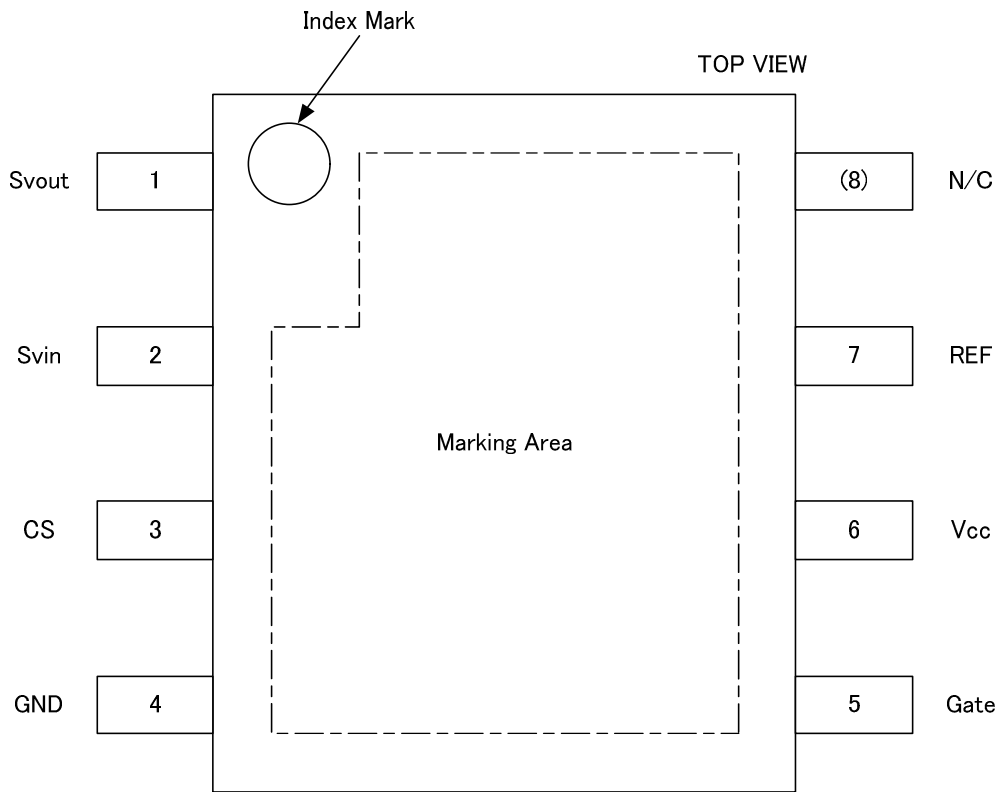

Package : SOP8J

## 1.4 Pin functions

Pin No.	Symbol	Name
1	Svout	Zero current detection pin
2	Svin	Zero current reference pin
3	CS	Current sense pin
4	GND	Ground pin
5	Gate	The output pin for main a MOSFET drive
6	Vcc	IC power supply pin
7	REF	Dimming pin
8	N/C	No Connect

## 2. Explanation of basic operations

The MV1012SC is a critical conduction mode (CRM) step-down chopper control IC. Figure 1 shows the circuit configuration. Figure 2 shows the waveforms of currents flowing to the MOSFET and the diode, represented by  $I_D$  and  $I_F$ , respectively. In a general CRM step-down chopper circuit, the MOSFET is turned on after the  $I_F$  becomes zero, leaving little recovery current for the diode and lower losses and noises than a PWM circuit. Meanwhile, disadvantageously, the oscillation frequency changes dramatically as the output current (LED current) changes, resulting in poorer dimming characteristics and efficiency.

The MV1012SC detects  $I_D$ , converted to a voltage, with the current detection pin (CS pin). When it reaches the CS reference voltage, the MV1012SC turns the MOSFET off (peak current detection). The IC performs CRM control in this way: When the diode current  $I_F$  becomes zero, the  $S_{vout}$  voltage falls below the  $S_{vin}$  voltage, so the IC detects this state (zero current detection) and turns the MOSFET on. The voltages on both ends of the choke (① and ② in Figure 2) are divided with resistors and input to the  $S_{vin}$  pin and the  $S_{vout}$  pin to achieve CRM operations without auxiliary winding. Additionally, the off-time modulation prevents the frequency increasing during dimming and achieves constant high efficiency and dimming characteristics during deep dimming. (See Section 5 [Dimming characteristics] on page 19.)

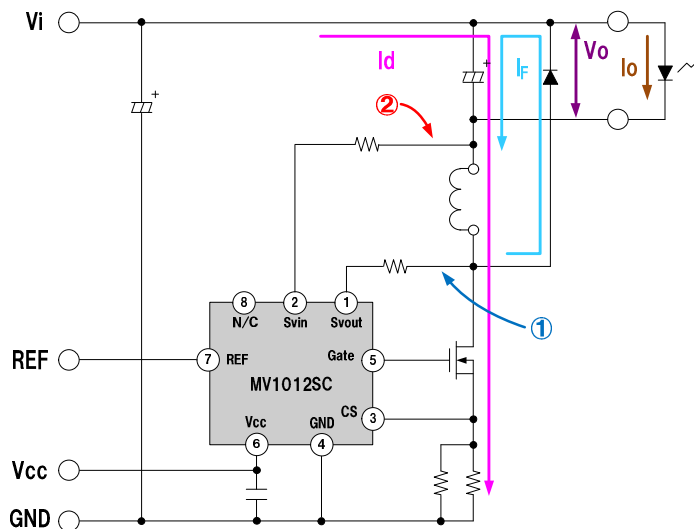

Figure 1 CRM step-down chopper circuit

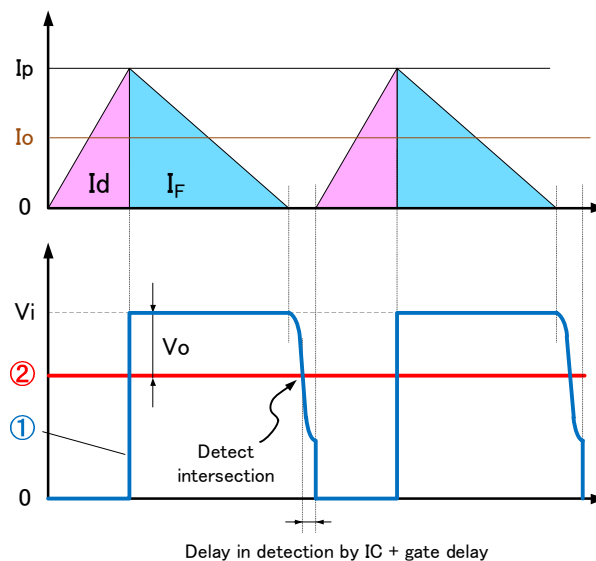

Figure 2 MOSFET and diode current waveforms of the CRM step-down chopper and voltage waveforms on both ends of the choke

## 2.1 Starting sequence

The logic circuit in the MV1012SC starts up when a voltage equal to or exceeding the starting voltage ( $V_{cc\_start}$ ) is supplied to the Vcc pin from an external power supply. To ensure stable operations, the signal should be sent to the REF pin when the Vcc voltage is equal to or greater than the  $V_{cc\_start}$ .

Figure 3 shows an example of a starting operation in the Vcc → REF sequence, using the circuit configuration shown in Figure 1.

In a normal start operation, oscillations start when the Vcc voltage reaches  $V_{cc\_start}$  and the  $V_{REF}$  voltage reaches the oscillation-off REF pin threshold voltage ( $V_{th\_REF\_sp}$ ). As the output voltage rises, the Svin voltage crosses the Svout voltage, enabling zero current detection. (Figure 3(a) Starting operation OK)

When it is difficult to charge the output capacitor—for instance, when the resistance of the gate resistor R4 is large or when the resistance of a dummy resistor connected in parallel with LED is small—the output voltage may not rise after oscillation has started and zero current detection may be disabled. When zero current detection cannot be performed, the IC is forcibly switched over to the restart operation, in which the minimum on-time and maximum off-time are used, instead of the normal peak current detection operation. When zero current detection is left disabled, the restart operation continues and LED will not light. (Figure 3(b) Starting operation NG)

Be sure to measure the Svin and Svout voltages at the start of the actual apparatus to confirm that zero current detection is enabled.

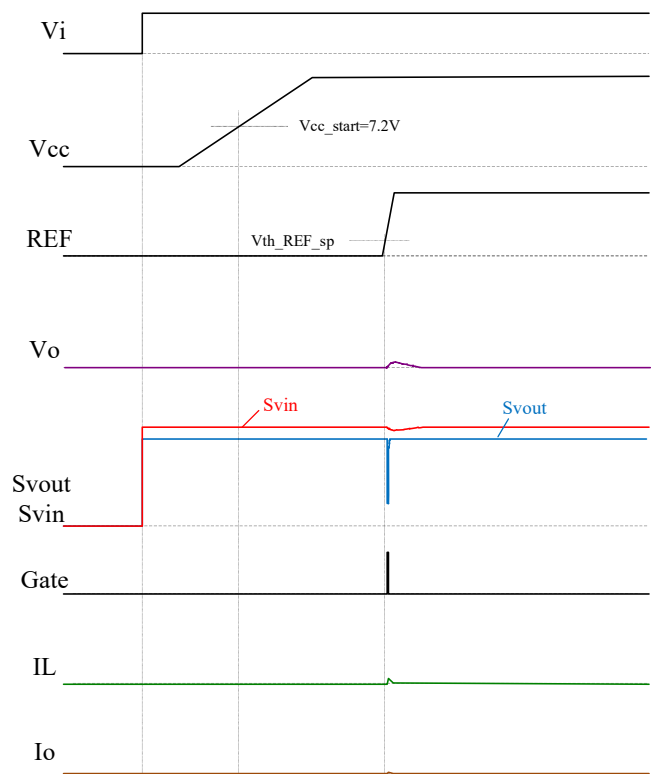
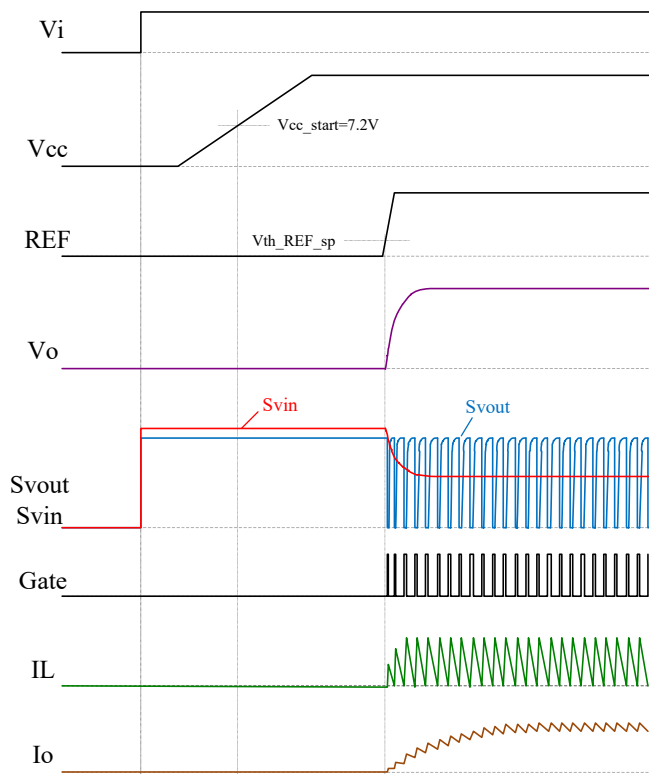

Figure 3(a) Starting operation OK

Figure 3(b) Starting operation NG



## 3. Component selection procedure and calculation method

The calculation is an estimate. In an actual circuit, errors may occur for various reasons, including the characteristics of individual parts and IC detection delays. Be sure to check with the actual apparatus and to make any adjustments needed.

When using an oscilloscope to verify waveforms, note that the waveform and characteristics change depending on probe capacitance. In particular, pay close attention when measuring the Svin, Svout, and CS pins, and D-S of the MOSFET.

Unless otherwise specified, the figures used in this document are typical values.

### 3.1 Basic circuit configuration

Figure 4 shows the basic circuit configuration. Figure 5 shows the basic operation waveforms.

As shown in Figure 4, detecting the voltages on both ends of the choke eliminates the need for an auxiliary winding and enables a simple, low-cost circuit configuration.

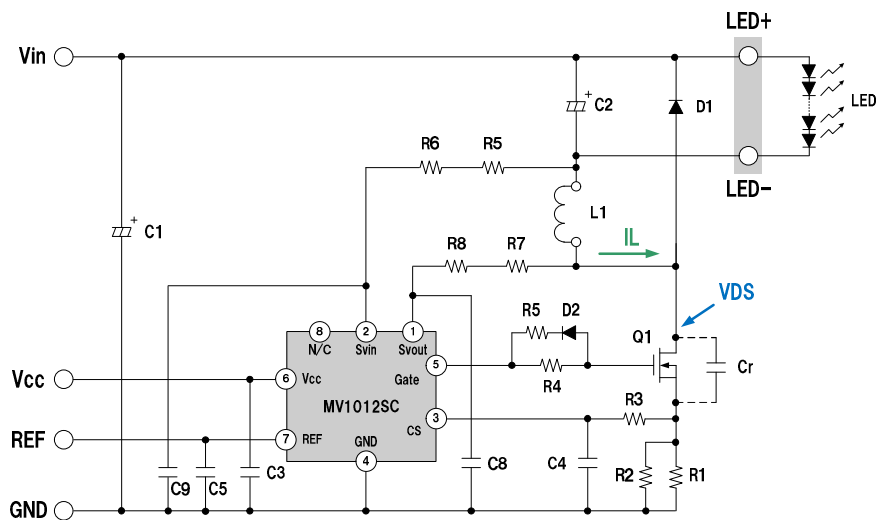

Figure 4 Basic circuit configuration

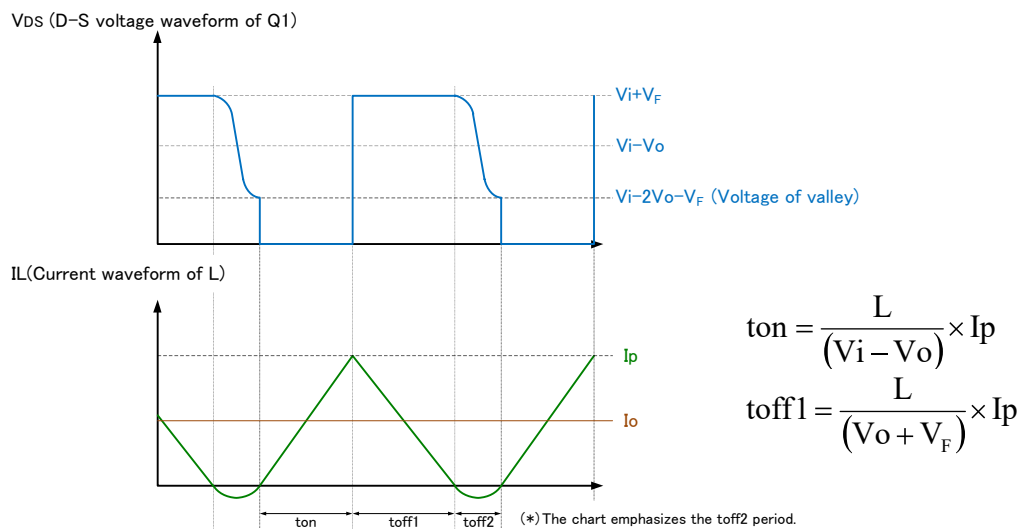
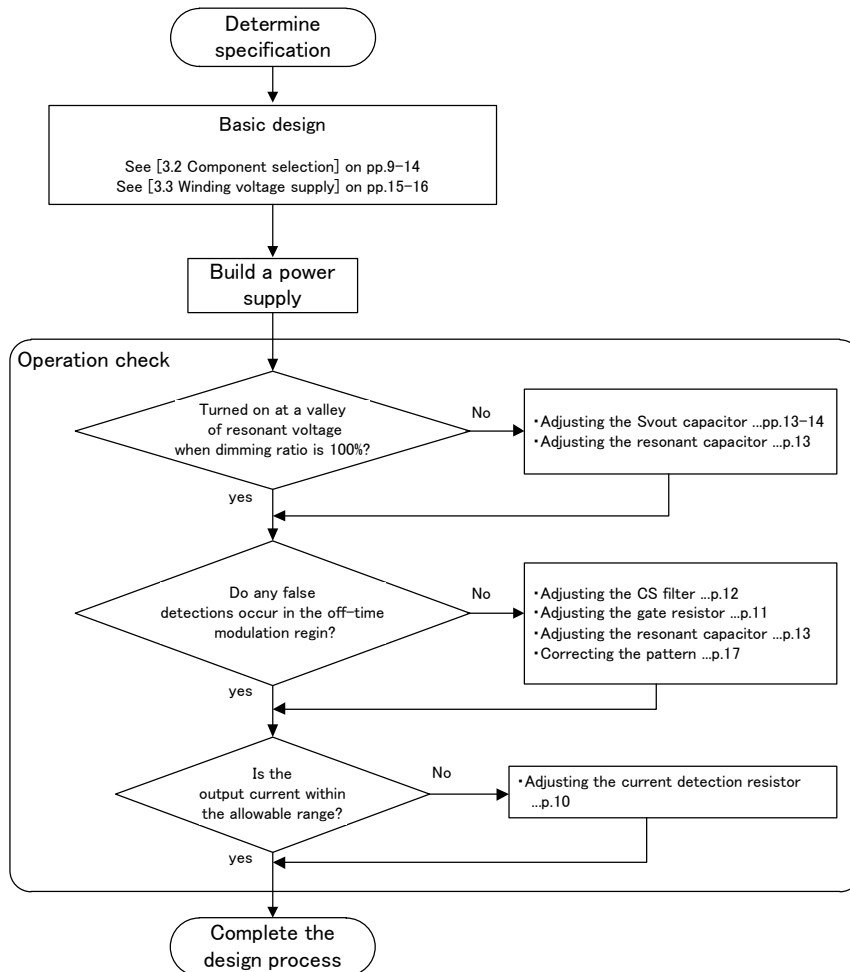

Figure 5 Basic operation waveforms

## 3.2 Component selection

The chart below shows a design procedure, from determination of the specification to adjustment. The design procedure provided in this section is an example of electrical design.

During the design process, be sure to comply with safety standards established by official bodies and with your company rules.



\* Repeat the operations check if a component constant changes after design has been completed.

### 3.2.1 MOSFET (Q1)

The MOSFET receives the voltages shown in Figure 5. The maximum applied voltage nearly equals the maximum input voltage. In actual use, voltage spikes may occur—for instance, due to parasitic inductance of the wiring pattern. Check with the actual apparatus and select a component with sufficient withstand voltage.

For a lighting apparatus that consumes a large amount of power, MOSFETs with low on-resistance offer advantages. When power consumption is small, MOSFETs with small capacitance, such as Ciss and Coss, help achieve highly efficient and advantageous dimming characteristics.

IC power consumption is the product of the input voltage and current consumption. Current consumption is the sum of the logic current and the gate drive current. Select MOSFETs that have the lowest possible gate capacitance. (See Table 1 Recommended MOSFETs.)

Table 1 Recommended MOSFETs (as of January 2015)

Product name	Withstand voltage (V)	Id (A)	Ron (typ)	Ron (max)	Qg (nC)	Ciss (pF)	Coss (pF)	Manufacturer	Package
P3B28HP2	280	3	1.7	2	3.6	120	25	Shindengen	FB
P6B28HP2		6	0.66	0.85	5.7	240	43	Shindengen	FB
P1R5B40HP2	400	1.5	4.2	5	3.9	120	20	Shindengen	FB
P4B40HP2		4	1.54	1.9	6.5	245	33	Shindengen	FB
P1B52HP2	525	1	6	7.2	4.3	125	20	Shindengen	FB
P5B52HP2		5	1.4	1.7	10.5	400	45	Shindengen	FB
P6B52HP2		6	1.1	1.35	15	520	58	Shindengen	FB
P0R5B60HP2	600	0.5	8.3	10	4.3	120	18	Shindengen	FB

### 3.2.2 Fly-wheel diode (D1)

Just as with MOSFETs, the fly-wheel diode must have withstand voltage greater than the input voltage. Additionally, select a fast recovery diode (FRD) suitable for high-speed switching with trr of around 100 nsec or less. (See Table 2 Recommended fly-wheel diodes.)

Table 2 Recommended fly-wheel diodes (as of January 2015)

Product name	Withstand voltage (V)	Io (A)	V <sub>F</sub> (V)	C <sub>j</sub> (pF)	trr (ns)	Manufacturer	Package
D1FL20U	200	1.1	0.98	-	35	Shindengen	1F
D2FL20U		1.5	0.98	-	35	Shindengen	2F
D1FL40U	400	1.5	1.2	11	25	Shindengen	1F
D2FL40		1.3	1.3	-	50	Shindengen	2F
D1FK60	600	0.8	1.3	11	75	Shindengen	1F
D2FK60		1.5	1.3	16	75	Shindengen	2F

### 3.2.3 Current detection resistor (R1 and R2)

The current detection threshold of the CS pin should be V<sub>th\_CS</sub> = 0.495 V, and R1/R2 = R<sub>cs</sub>. In Figure 5, when toff2 is significantly less than ton or toff1, the peak current of Id, Ip, is double the output current Io. Thus, the R<sub>cs</sub> is calculated using the output current when the dimming ratio is 100%, Io (max), as follows:

$$R_{cs} = \frac{V_{th\_CS}}{I_p} = \frac{0.495}{2 \times I_o(max)}$$

In actual use, the current will vary slightly from the calculated value due to toff2 and detection delay. Adjust to the appropriate resistance with the actual apparatus.

### 3.2.4 Inductor (L1)

Inductance is calculated, ignoring  $t_{off2}$ , as follows, where the input voltage is represented by  $V_i$ , the output voltage (LED voltage) by  $V_o$ , the switching frequency by  $f$ , the inductance by  $L$ , the forward voltage of the fly-wheel diode D1 by  $V_F$ :

$$L = \frac{(V_i - V_o) \times (V_o + V_F)}{2 \times f \times I_o \times (V_i + V_F)}$$

The switching frequency changes with changes in input voltage and with dimming.

A general inductor has the DC bias characteristics shown in Figure 6(a). As current increases, inductance decreases. This results in the MOSFET current waveform indicated by a solid line in Figure 6(b). The output current  $I_o$  is slightly smaller than the calculated value.

The inductor receives the peak current  $I_p$  about twice larger than the output current  $I_o$  and thus pay attention to a decrease in inductance with  $I_p$  when selecting the inductor.

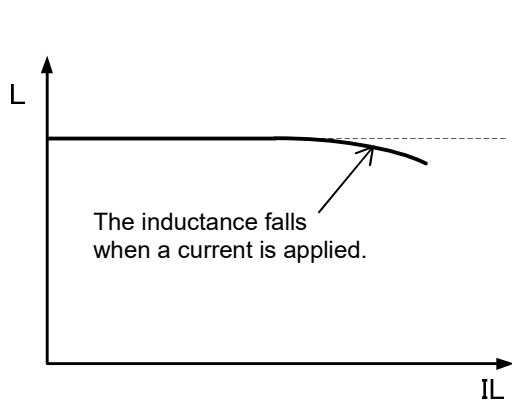

Figure 6(a) Inductor's DC bias characteristics

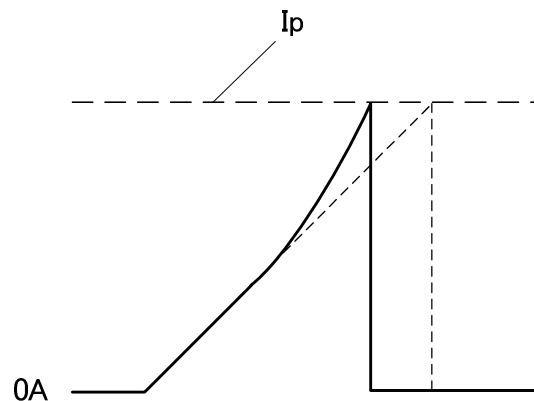

Figure 6(b) MOSFET current waveform at inductance drop

### 3.2.5 Gate drive circuit (R4, R9, and D2)

In the IC, the gate charging current ( $I_{G\_source}$ ) is limited to about 40 mA and the discharge current ( $I_{G\_sink}$ ) to about 425 mA. Thus, the circuit can be used with  $R4 = 0 \Omega$ —i.e., with a direct connection. Using  $R4$  enables adjustment for delays, noise reduction, and improved dimming characteristics. However, if the resistance of  $R4$  is too large, zero current detection may not be performed once the restart operation starts. The restart operation may continue. To determine the resistance of  $R4$ , be sure to confirm that zero current detection can be performed even when oscillation starts with the REF voltage slowed up

When  $R4$  is added to the circuit, the discharge current is limited. To achieve advantageous constant-current characteristics, the delay needs to be small; this means a discharge diode is required,  $D2$ . The discharge current can be adjusted with resistor  $R9$ .

The charge and discharge currents above are levels with  $V_{cc} = 9 V$ . They will vary depending on  $V_{cc}$  value.

### 3.2.6 Resistors for Svin and Svout pins (R5, R6, R7 and R8)

The Svin and Svout pins are used for comparator input to detect voltage inversions on both ends of L1 to determine switching timing on (zero current detection). To ensure advantageous comparator characteristics, the input voltage into the pins should not exceed 3.5 V. The voltages on both ends of L are very high; voltage dividing resistors (R5, R6, R7, and R8) are required, as shown in the circuit diagram (Figure 7).

Due to the configuration of the basic circuit, an LED leak current flows via the voltage dividing resistors (R5 to R8) and the IC internal resistor (25 kΩ). To reduce output current when the IC is not operating and the dimming ratio is at its minimum, use a winding voltage supply, as described in Section 3.3.

Figure 7 shows the voltage waveforms of the Svin and Svout pins and the internal circuit diagram.

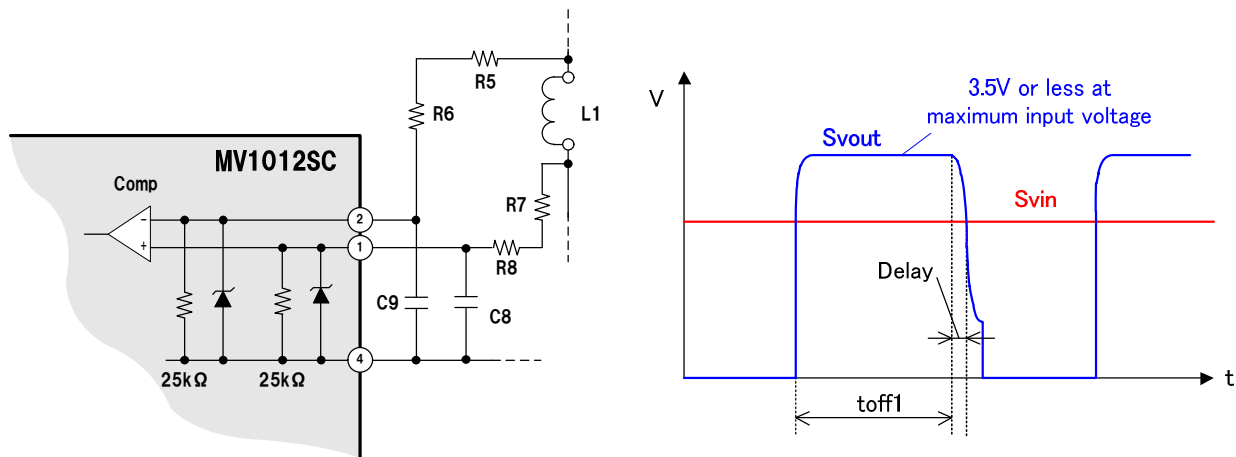

Figure 7 Zero current detecting operation waveforms and internal circuit diagram

Select R7 and R8 so that the Svout pin voltage is around 3 V when the input voltage is at maximum. Use the following formula:

$$R7 + R8 = \frac{25k \times (Vi_{\text{max}} + V_F)}{3} - 25k$$

Select R5 and R6 with resistance about 5% lower than R7 and R8. (See Section 6.2 [LED short circuits] on page 28.)

Select highly accurate resistors as R5, R6, R7, and R8 (accuracy ±1% or better).

When the output voltage  $V_o$  does not exceed 10% of the maximum input voltage  $V_i$ , zero current detection may be disabled. In that case, use the winding voltage supply, as described in Section 3.3 on page 15.

### 3.2.7 CS pin filter (R3 and C4)

R3 and C4 are filters used to shield the CS pin from noise. Adjusting R3 to range between 0 Ω and several kΩ and C4 between 10 pF and 100 pF will reduce false detections of off-timing due to switching-on noise in the off-time modulation region. When adjusting the filter constants, check for false detections on the actual apparatus using as many different REF pin voltage  $V_{REF}$  settings as possible within the REF voltage range given in the specification. (For details, see Section 5.1.2 [[B] Off-time modulation range] on pages 21 to 22.)

If the filter constants set are too large, the detection delay will grow, along with the change in output current due to the output current setting and the input voltage. Reselect current detection resistors (R1 and R2) or the inductor, if necessary.

### 3.2.8 Vcc pin smoothing capacitor (C3)

C3 is a capacitor used to stabilize the power supply voltage of the Vcc pin. Check the Vcc pin voltage waveform and select a capacitor with capacitance of 0.1 uF or more. A very large capacitance value will length start times. Check with the actual apparatus.

### 3.2.9 REF pin capacitor (C5)

C5 is a capacitor used to prevent unintended noise-induced operations. The capacitance of the capacitor should be around 1000 pF. For dimming methods, see Section 5 [Dimming characteristics] on page 19.

### 3.2.10 Svin pin capacitor (C9)

C9 is a capacitor used to prevent unintended noise-induced operations. The capacitance of the capacitor should be around 1000 pF.

### 3.2.11 Resonant capacitor (Cr)

In addition to enabling adjustments of the resonant period, Cr will reduce switching-off noise. However, note that it may also increase switching-on noise. If Cr is too large, dimming characteristics and efficiency may be degraded. We recommend against using this capacitor. If you wish to use it, make adjustments with the actual apparatus to minimize capacitance.

### 3.2.12 Input capacitor (C1) and Output capacitor (C2)

Select input and output capacitors after considering allowable ripple current, life, output holding time, etc. The ripple current of a capacitor is calculated by the following formulas:

Ripple current of input capacitor

$$I_{ripin} = I_p \times \sqrt{D \times \left( \frac{1}{3} - \frac{D}{4} \right)}$$

Ripple current of output capacitor

$$I_{ripout} = \frac{I_o}{\sqrt{3}}$$

Where D represents the switching duty cycle.

D is obtained using the formula,  $D = V_o/V_i$ , based on the relationship between input and output voltages.

In the case of an input capacitor, ripple currents are added from input circuit devices, such as the full wave rectifier and PFC. Consider these as well when selecting the capacitor.

### 3.2.13 Svout pin capacitor (C8)

C8 is a capacitor used to adjust the delay shown in Figure 7 and to the on-timing. For a discussion of adjusting on-timing using C8, see [Additional explanation of resonant period in quasi-resonant operation] on page 14.

C8 also prevents unintended noise-induced operations. Adjust the capacitance to around 10 to 100 pF with the actual apparatus.

Additional explanation of resonant period in quasi-resonant operation

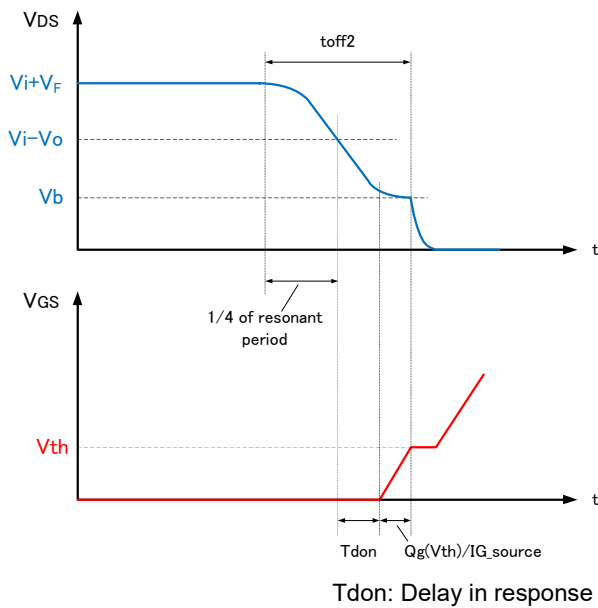

Example of gate charge characteristics

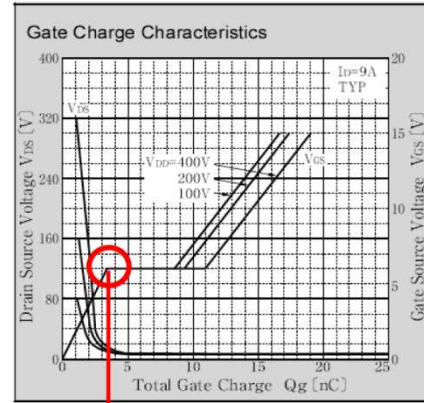

Qg (Vth): Accumulated charge until the voltage reaches the gate threshold

Figure 8 Adjusting the delay

Ideally, the MOSFET should be turned on at a valley of resonance as shown in Figure 8. The corresponding condition is expressed by the following formula:

$$\frac{1}{4} \times 2\pi\sqrt{L \times (Cr + Coss + Cj)} = Td_{on} + \frac{Qg(Vth)}{Ig}$$

- Coss: Output capacitance of MOSFET
- Cr: Capacitance of D-S capacitor
- Cj: Junction capacitance of fly-wheel diode

Since  $V_b = V_i - 2V_o - V_f$ , switching losses are minimized. While the condition above may not be completely fulfilled in actual use, MOSFETs do not need to be switched on precisely at a valley. If the on-timing is far from the valley, it can be adjusted as follows:

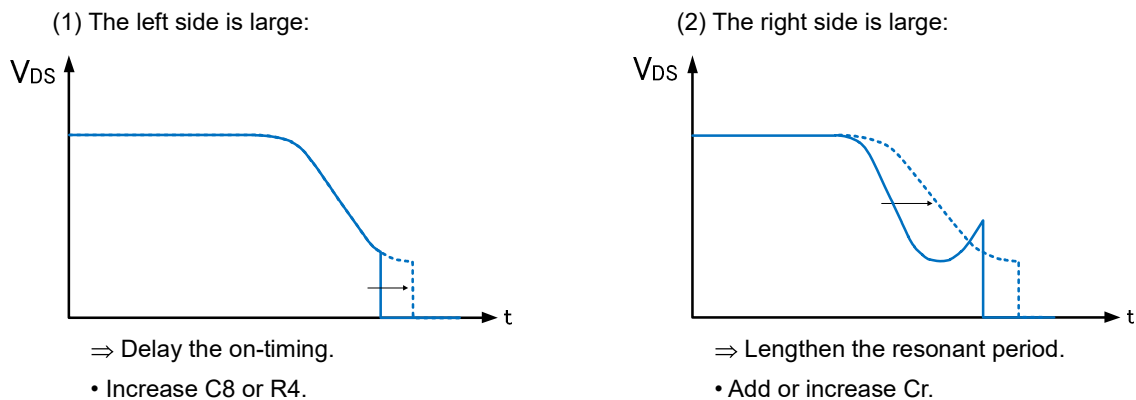

## 3.3 Winding voltage supply

### 3.3.1 Configuration of a winding voltage supply

Using an auxiliary winding shown in Figure 9 protects the MV1012SC against output overvoltages caused (for instance) by LED open circuits. Additionally, the operation is ensured even with specifications at which the output voltage  $V_o$  does not exceed 10% of the maximum input voltage  $V_i$ . (See Section 3.2.6 [Selecting resistors for  $S_{vin}$  and  $S_{vout}$  pins] on page 12.)

When selecting components, select an auxiliary winding and a rectifier diode for the auxiliary winding.

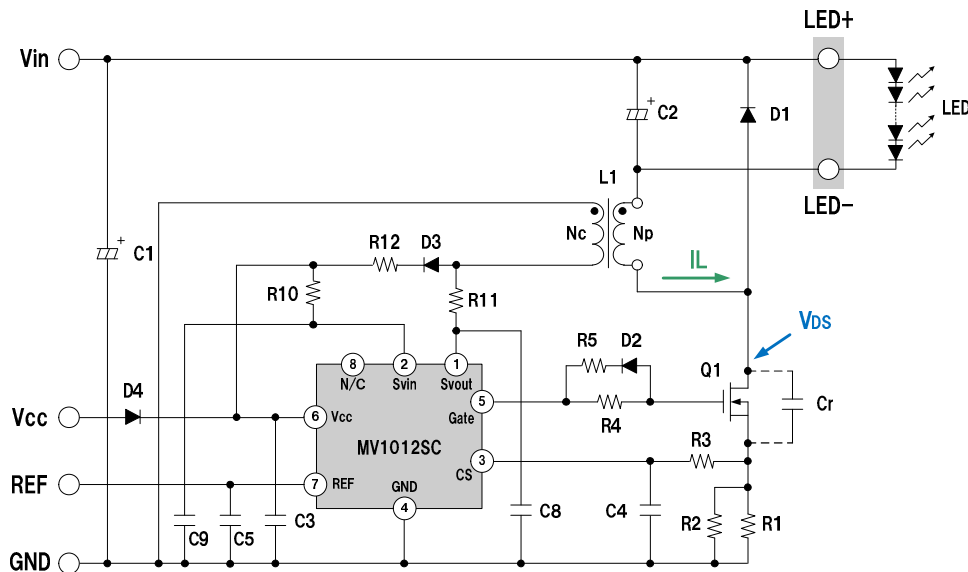

Figure 9 Configuration of a winding voltage supply

### 3.3.2 Selecting the auxiliary winding ( $N_c$ )

If  $V_c$  represents the auxiliary winding voltage rectified and applied to the  $V_{cc}$  pin,  $V_c$  is obtained by the formula given below. Considering changes in  $V_o$  due to dimming and changes in  $V_F$  of the LED, select the turn ratio at which  $V_c$  voltage falls within the range between 10 V and 16 V.

$$\frac{N_c}{N_p} \cong \frac{V_c}{V_o}$$

$N_p$ : Number of turns of inductor L1 [T]  
 $N_c$ : Number of turns of auxiliary winding [T]

Depending on the turn ratio or the coupling condition of the winding, a surge voltage is generated in the auxiliary winding, and  $V_c$  voltage may exceed the set level. Check with the actual apparatus to determine whether the  $V_c$  voltage is between 10 V and 16 V.

### 3.3.3 Selecting the auxiliary winding rectifier diode (D3)

$V_r$ , a reverse voltage represented by the following formula, is applied to D3. Note the withstand voltage when selecting this component.

$$V_r = V_i \times \frac{N_c}{N_p}$$

When the input voltage is at maximum, the reverse voltage applied to D3 is also at maximum. Use a fast recovery diode (FRD) for D3.

(See Table 3 Recommended rectifier diodes.)



Table 3 Recommended rectifier diodes (as of January 2015)

Product name	Withstand voltage (V)	Io (A)	V <sub>F</sub> (V)	C <sub>j</sub> (pF)	trr (ns)	Manufacturer	Package
M1FL20U	200	1.1	0.98	-	35	Shindengen	M1F
M1FL40U	400	1.5	1.2	11	25	Shindengen	M1F
D1FK60	600	0.8	1.3	11	75	Shindengen	1F

Placing a resistor R12 in series with D3 may reduce the effects of the surge voltage of the auxiliary winding on the Vcc pin, and reduce Vc voltage increased by the surge voltage.

R10 should be 1 MΩ; R11 should be 220 kΩ.

The Svin and Svout pin waveforms are as shown in Figure 10 when an auxiliary winding is used.

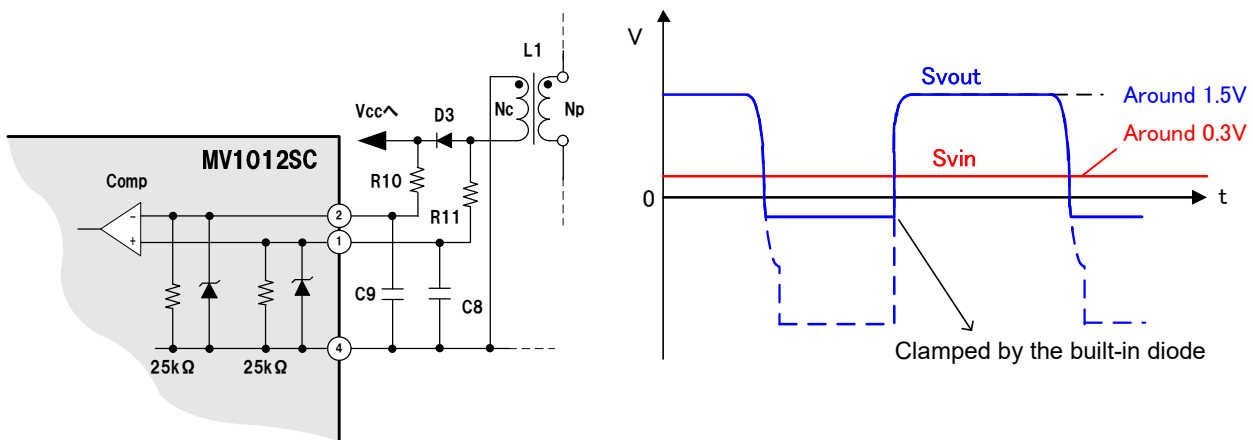

Figure 10 Waveforms of Svin and Svout pins when an auxiliary winding is used

### 3.3.4 LED open-circuit protection using auxiliary winding

Using the auxiliary winding of the inductor L1 shown in Figure 9 provides protection against output overvoltages due (for instance) to LED open-circuit. The Vcc pin performs the latch-off function when detecting an overvoltage. It disables the operation when the Vcc pin voltage reaches 20.7 V (typical). If the auxiliary winding is wound with the polarity shown in Figure 9, the auxiliary winding voltage is proportional to output voltage; thus, it is possible to indirectly detect an overvoltage caused by LED open-circuit and to stop the operation.

The following formula gives Vovp, an output voltage at the time of latch-off:

$$V_{ovp} = \frac{20.7}{V_c} \times V_o$$

If the difference between the input voltage Vi and the output voltage Vo is small, the Vcc voltage may not reach 20.7 V. In this case, LED open-circuit protection by the auxiliary winding may fail.

## 4. Cautions on pattern designing

### 4.1 Cautions

Figure 11 shows the same circuit shown in Figure 4, rewritten after accounting for pattern design. Consider the four items below for pattern design. Due to the potential for false detection, pay special attention to items 1 and 2.

1. The shaded area indicates the main circuit through which the switching current flows. To make this area as small as possible, wire with the shortest possible tracks, prioritizing this aspect over other aspects.
2. The area enclosed with a dotted line indicates the control circuit. Strive to minimize the effects of noise and magnetic flux of the main circuit on the control circuit. The control circuit should have one GND terminal, connected to a stable part of the main circuit, such as a minus terminal of the input capacitor. In particular, make sure that the tracks to input signals to pins such as REF, Svin, Svout, and CS pins are kept at a distance from high-voltage circuits.
3. Magnetic flux is present around the inductor. Use a shield type inductor with a small flux leak. Make sure that the signal tracks are not placed just below the inductor.
4. Wire the tracks for the Svin and Svout pins as close to parallel as possible.

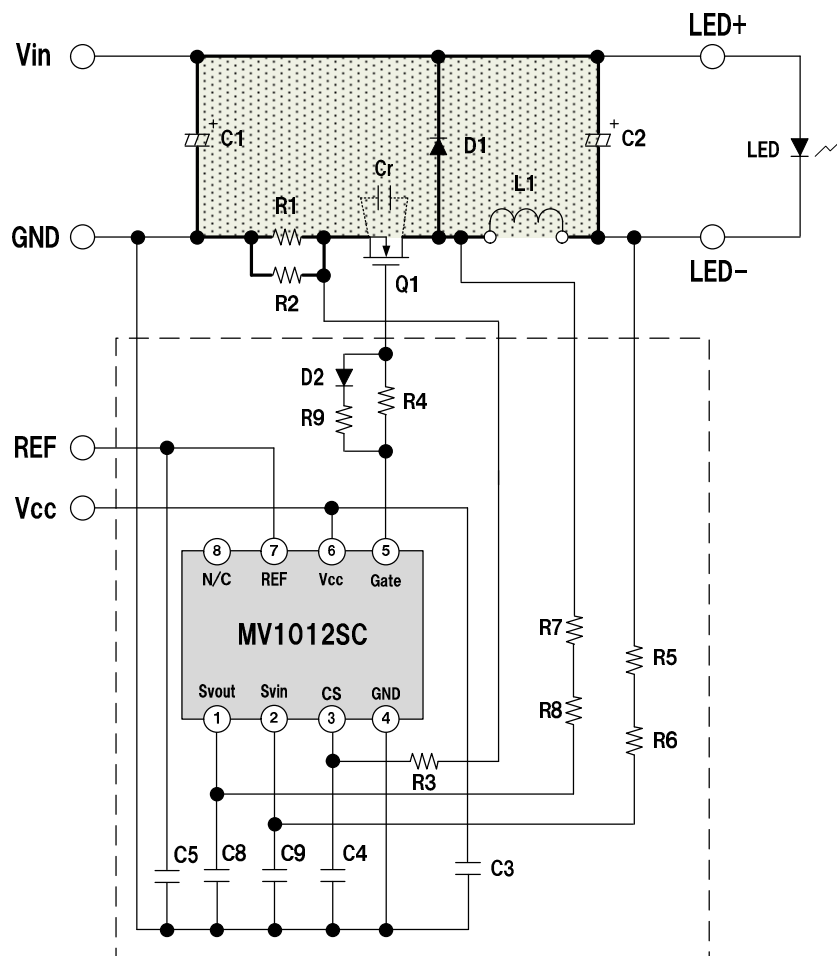
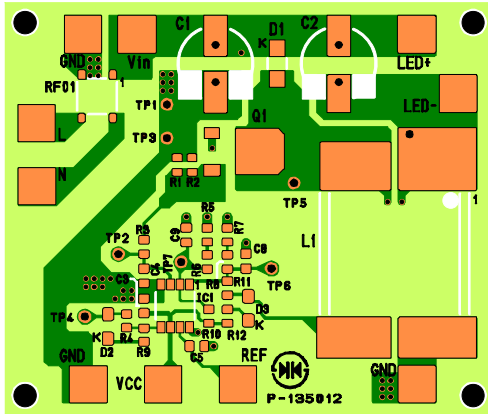

Figure 11 Circuit diagram accounting for pattern design

## 4.2 PCB pattern example

The diagram below shows an example of a pattern layout using our sample board. The pattern on the sample board lacks an input fuse and input line filter. Be sure to add these components for actual applications.

<Front>



<Back>

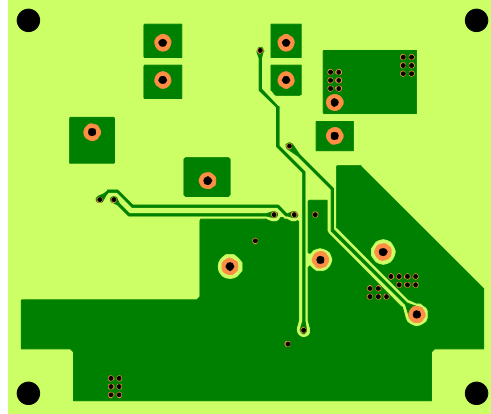

[PCB size: 55 mm H x 65 mm W]

The above pattern is an example. It does not guarantee actual operation. Be sure to check actual operation with the actual apparatus.

## 5. Dimming characteristics

Figure 12 shows typical dimming characteristics for the MV1012SC.

Since the current detection threshold changes with REF pin voltage  $V_{REF}$ , the output current can be adjusted using  $V_{REF}$ . Apply a DC voltage to the REF pin and adjust the voltage to enable linear dimming control. In addition, sending a PWM signal of 1 kHz or less to the REF pin and controlling the duty cycle enables PWM dimming. Reducing  $V_{REF}$  automatically switches operations from critical conduction mode to discontinuous conduction mode, allowing adjustments of the output current to very low levels, even with linear dimming.

[A] frequency modulation region and [B] off-time modulation region shown in Figure 12 are automatically switched over based on a comparison of  $T_{off}$  (CRM) and  $T_{off}$  (DCM) on the IC.  $T_{off}$  (CRM) is the off-time in critical conduction mode (sum of  $t_{off1}$  worked out by the formula in Figure 5 on page 8 and the resonant period  $t_{off2}$ ).  $T_{off}$  (DCM) is the forced off-time determined on the IC based on  $V_{REF}$ . When  $T_{off}$  (CRM) >  $T_{off}$  (DCM), the operating mode switches to the [A] frequency modulation region. When  $T_{off}$  (CRM) <  $T_{off}$  (DCM), the operating mode switches to the [B] off-time modulation region. The REF pin voltage for switchover changes with input/output conditions, choke inductance, and other parameters. Calculate the forced off-time  $T_{off}$  (DCM), using the following approximation formula as a guide.

$$T_{off}(\text{DCM}) \cong \frac{64.35}{45.9 \times V_{REF} - 9.9} \quad [\mu\text{s}] \quad (0.24\text{V} < V_{REF} < 0.7\text{V})$$

The lower chart in Figure 12 shows a graph of REF pin voltage and off-time. The red curve represents  $T_{off}$  (CRM). The green curve represents  $T_{off}$  (DCM).

If  $V_{REF}$  is equal to or below the oscillation-off REF pin threshold voltage ( $V_{th\_REF\_sp}$ ), the operation will switch to the [C] Oscillation off region.

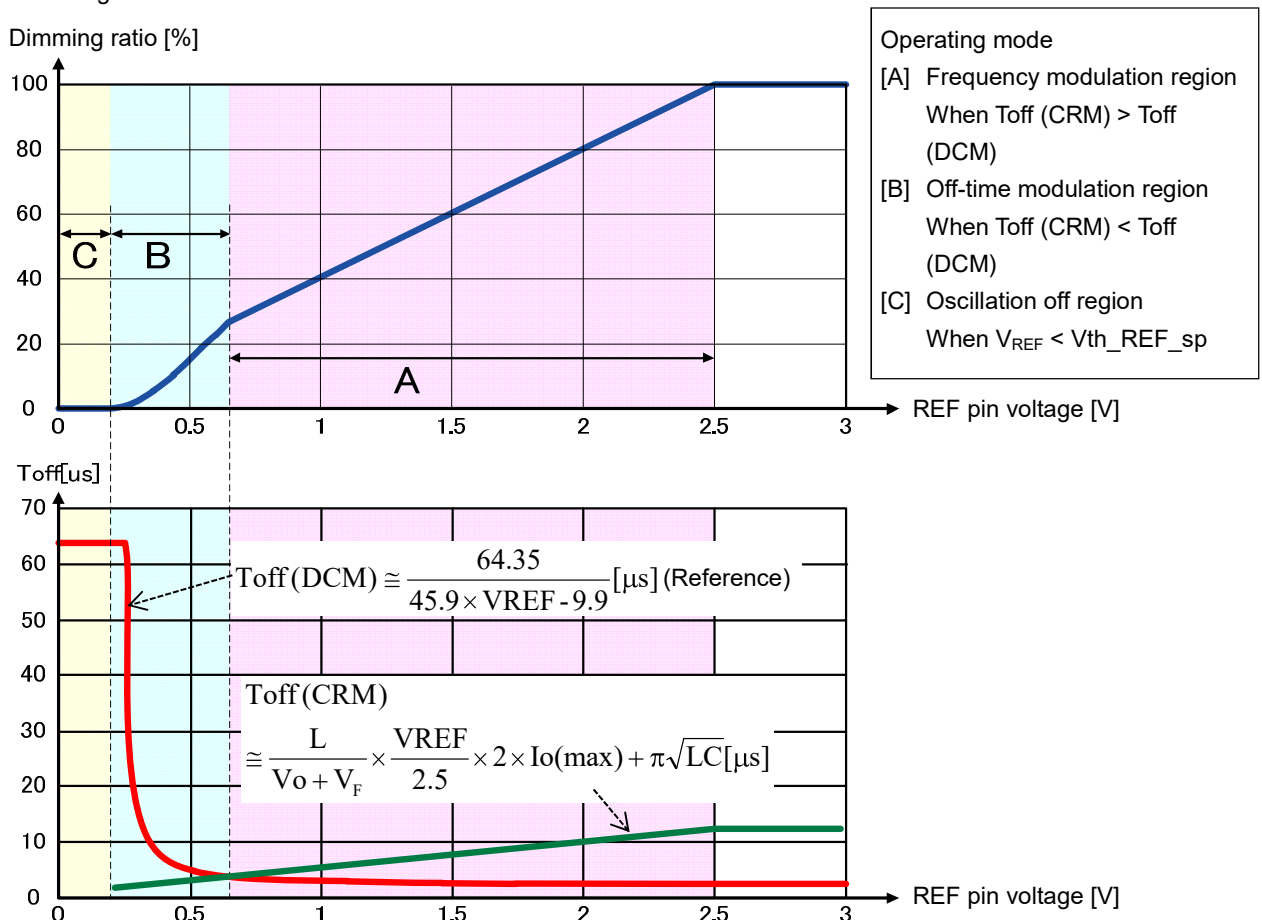

Figure 12 Relationship of REF pin voltage  $V_{REF}$  to dimming ratio and to off-time  $T_{off}$

## 5.1 Operation in each mode

### 5.1.1 [A] Frequency modulation region

The operation waveforms in the frequency modulation region are those in critical conduction mode shown in Figure 14. Figure 13 shows the internal circuit of the CS pin. Voltage  $1/5$  of  $V_{REF}$  is compared to current detection threshold voltage  $V_{th\_CS}$  (0.495V); the lower voltage is used as the CS pin reference voltage. In actual use, both  $V_{th\_CS}$  and  $V_{REF} \times 1/5$  will change slightly. To make sure  $V_{th\_CS}$  is used as the reference, set  $V_{REF}$  to 2.6 V or greater.

If resonant period  $T_{off2}$  is significantly less than  $t_{on}$  and  $t_{off1}$ ,  $I_L$  may be regarded as a triangle wave. Thus,  $I_o = 1/2 \times I_p$ , and output current  $I_o$  becomes proportional to  $V_{REF}$ . However, the oscillation frequency increases as  $V_{REF}$  decreases; the ratios of  $T_{off2}$  and detection delay to the period of a cycle will therefore increase. In this case, the proportional relationship between  $I_o$  and  $V_{REF}$  may change somewhat.

REF pin voltage  $V_{REF}$ : 2.6 V or more

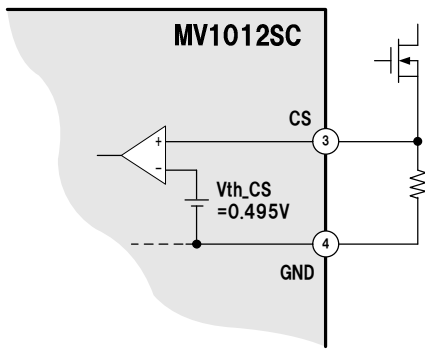

REF pin voltage  $V_{REF}$ : 2.5 V or less

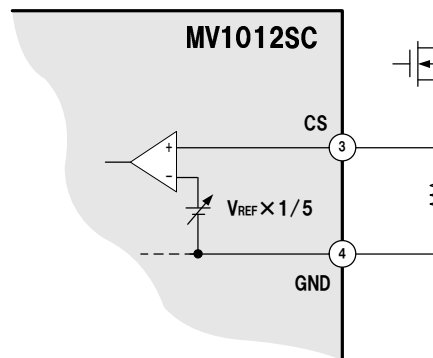

Figure 13 CS pin internal circuit diagram

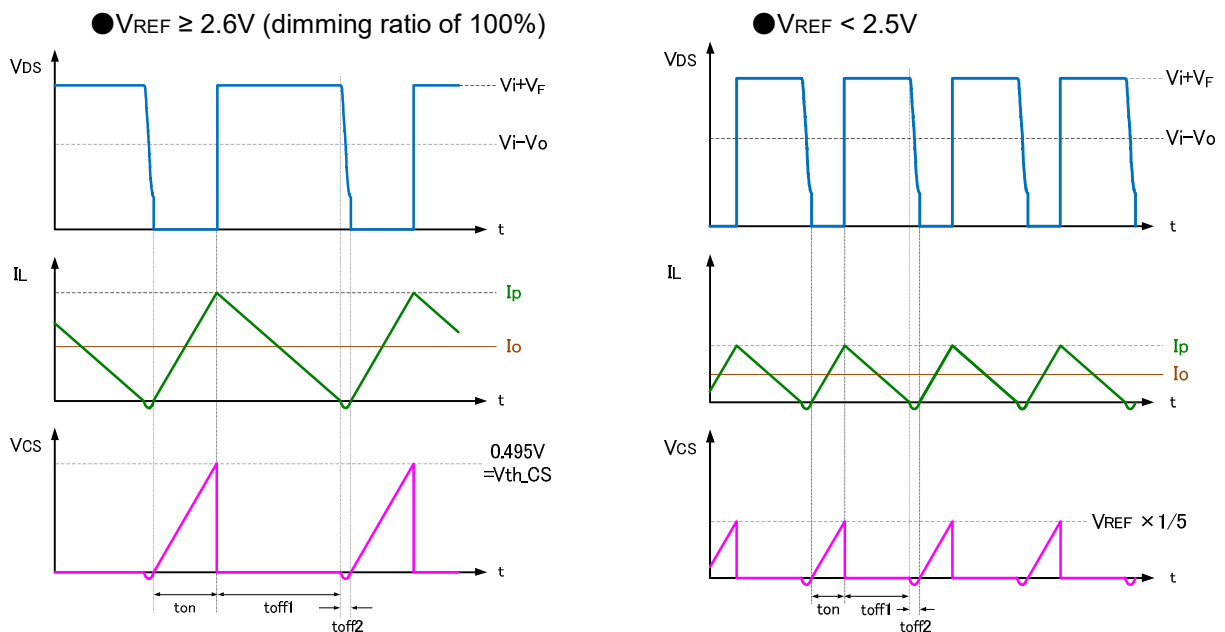

Figure 14 Operation waveforms in [A] frequency modulation region

## 5.1.2 [B] Off-time modulation region

Operation waveforms in the off-time modulation region are those in discontinuous conduction mode shown in Figure 15. Output current can be controlled to very low levels by increasing the forced off-time  $T_{off}$  (DCM) as  $V_{REF}$  falls. The forced off-time includes  $t_{off1}$ , the period during which a current flows to D1. As shown by the formula in Figure 5,  $t_{off1}$  depends on  $V_o$ . Therefore, if  $V_o$  changes,  $I_o$  in the [B] region will also change.

The reference voltage for the CS pin is  $1/5$  of  $V_{REF}$  in the [B] region as well, and therefore lower than in the [A] region. Thus, the circuit is more likely to be affected by noise in the [B] region. The MOSFET is more likely to switch off at a timing that varies from the time of peak current detection. The switching-on timing does not fall on a valley of the resonant voltage. If the  $V_{DS}$  voltage at switching-on exceeds  $V_b$ , switching-on noise will increase. In actual use, after the switch is turned on, there will be a leading edge blanking (LEB) period in which noise is rejected. During LEB period, the MOSFET cannot be turned off. (Figure 16(b)) Even during the LEB period, when switching-on noise or noise from an external circuit exceeds the reference voltage, such noise will lead to false detection, and the MOSFET is turned off. (Figure 17(b)) As a result,  $I_o$  drops below the optimal level. Depending on the timing of the noise, the LED light may flicker.

If  $C_{oss}$  of MOSFET,  $C_r$  of the resonant capacitor or  $C_j$  of the fly-wheel diode is large, the switching-on noise will also be large. If switching-on noise causes false detection, adjust the CS filter (page 12), adjust the gate resistance (page 11), or reselect the components above.

To quickly check whether false detection occurred, use many different  $V_{REF}$  settings to check for an apparently short  $T_{on}$ , which is not the peak current detection. Measurements may be incorrect if you measure the  $V_{cs}$  or  $V_{DS}$  voltage. We recommend measuring just the gate pin waveform.

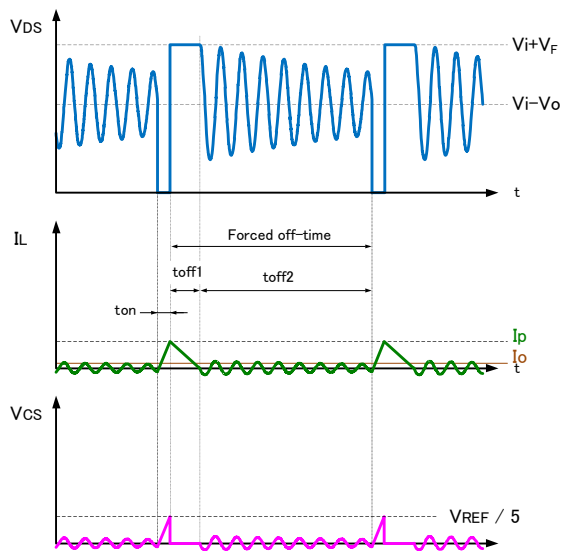
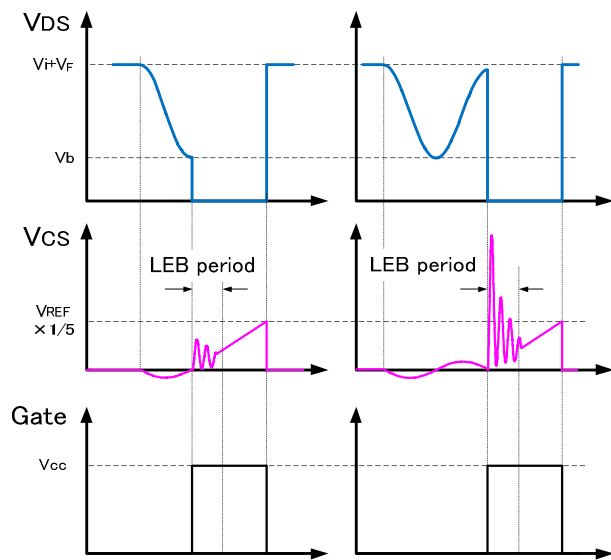

Figure 15 Operation waveform in the [B] off-time modulation region



(a) Switched on when  $V_{DS} \approx V_b$  (b) Switched on when  $V_{DS} > V_b$

Figure 16 Example of switching-on noise caused by  $V_{DS}$

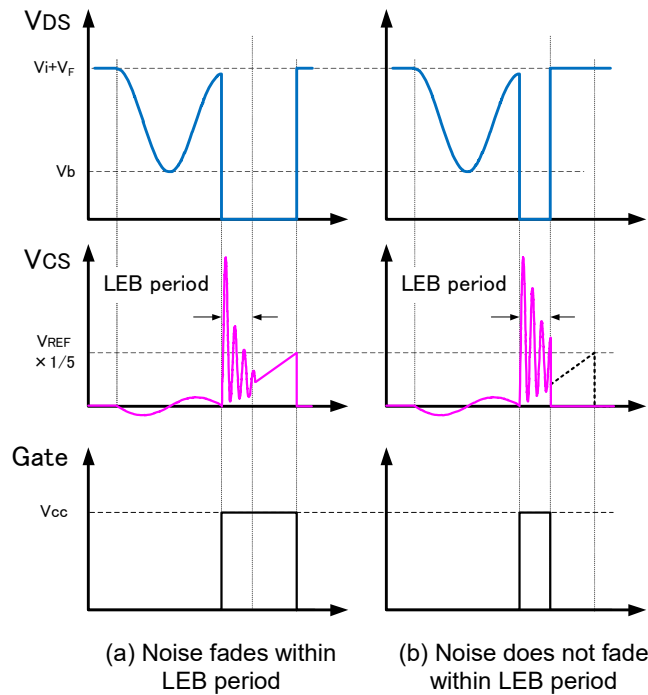

Figure 17 Example of false detection due to switching-on noise

The resonant current flowing in toff2 period also flows to the current detection resistor  $R_{cs}$ .  $V_{cs}$  oscillates around 0 V during the toff2 period. Even in case of the same  $V_{REF}$ ,  $I_o$  accuracy and smoothness of dimming characteristics may be degraded (see  $V_{REF}$  ripple: Small in Figure 19) if the on-time changes significantly depending on whether  $V_{cs}$  at on-timing exceeds 0 V, as shown in Figure 18.

The amplitude of  $V_{cs}$  during the toff2 period can be reduced by reducing the  $C_{oss}$  of MOSFET and the  $C_r$  of the resonant capacitor. Increasing the ripple voltage of  $V_{REF}$  averages any changes in the on-time and reduces  $V_{cs}$ -dependent changes in  $I_o$  at switching-on. (See  $V_{REF}$  ripple: Large in Figure 19.)

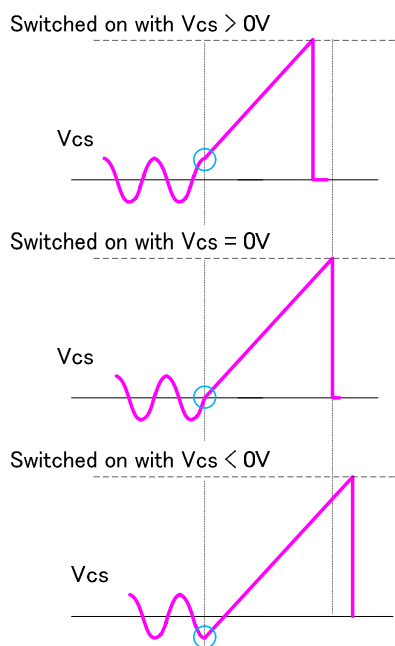

Figure 18 Changes in on-time determined by switching-on timing in the [B] region

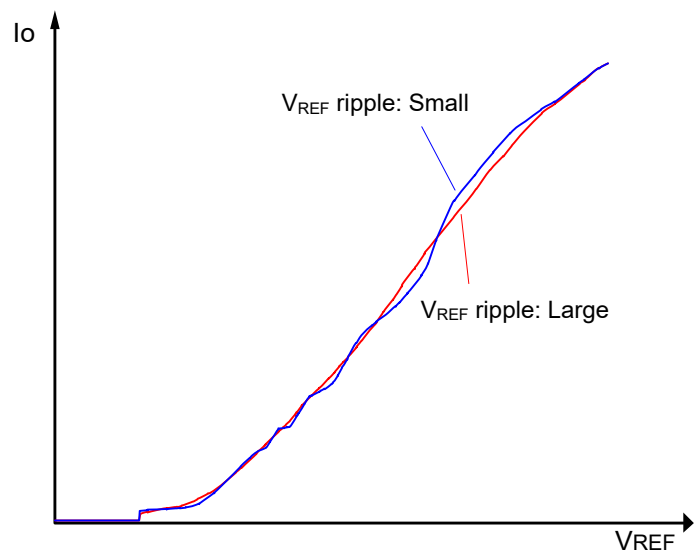

Figure 19 Example illustrating degraded smoothness of dimming characteristics

### 5.1.3 [C] Oscillation off region

The MV1012SC can stop gate output by holding the  $V_{REF}$  at or below the oscillation-off REF pin threshold voltage ( $V_{th\_REF\_sp}$ ). To turn the MOSFET completely off,  $I_o$  can be brought closer to zero than in the [B] region.

In the basic circuit configuration shown in Figure 4, a leakage current flows constantly via the internal resistors of the  $S_{vin}$  and  $S_{vout}$  pins. A leakage current is also present in the [A] and [B] regions. In the [C] region, in which the MOSFET is completely off,  $I_o$  is just the leakage current. The value of the leakage current is determined by the input/output voltage difference and the values of resistors R5 to R8. To eliminate the leakage current, use the circuit configuration with an auxiliary winding.

The standard values for  $V_{th\_REF\_sp}$  range from 0.15 V to 0.22 V. Set  $V_{REF}$  at or below 0.15 V if using the [C] region.

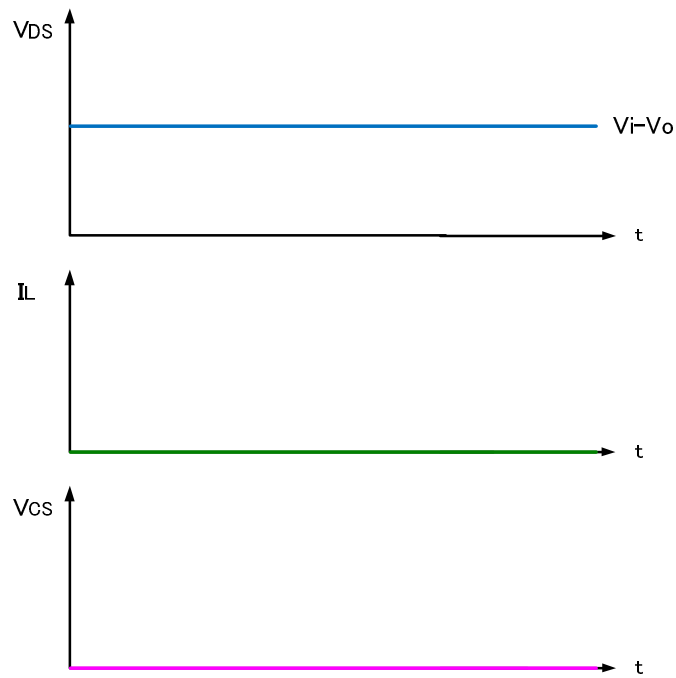

Figure 20 Operation waveform in the [C] Oscillation off region



## 5.2 PWM dimming

### 5.2.1 PWM dimming in 100% and oscillation off regions

PWM dimming can be performed by sending a PWM signal to the REF pin with  $V_{REF}$  in the 100% dimming ratio as the high level and  $V_{REF}$  in the oscillation off region as the low level. Frequency  $f$  and on-duty cycle  $Don$  of a PWM signal should be 1 kHz or less and 1% or more, respectively.

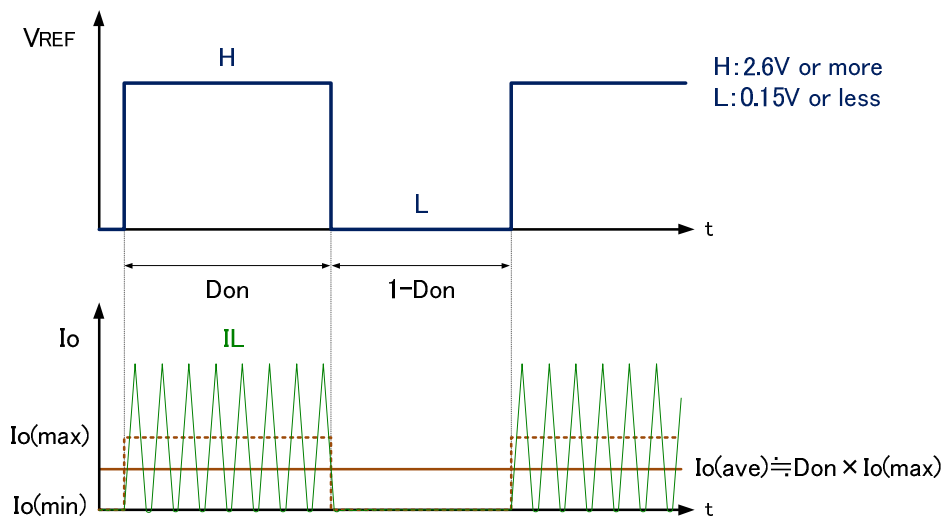

Figure 21 Example of PWM dimming operation

As shown in Figure 21, when a PWM signal with on-duty cycle of  $Don$  is applied to the REF pin,  $I_o$  becomes an average current  $I_o(ave) = Don \times I_o(max) + (1 - Don) \times I_o(min)$ . In actual use,  $I_o(min)$  is very small, and the equation may be rewritten to  $I_o(ave) \approx Don \times I_o(max)$ .

In PWM dimming, if the first switching-on timing in the H-level period is irregular, the practical  $Don$  will also become irregular and  $I_o$  will become unstable. The effect is especially significant if  $Don$  is small. To avoid this problem, the first switching-on timing in the H-level period of every cycle aligns with each other by detecting a change of  $V_{REF}$  from L level to H level and forcibly outputting an on-trigger. This function helps stabilize  $I_o(ave)$ , even if  $Don$  is small.

## 5.2.2 Combination of linear dimming and PWM dimming

Linear dimming and PWM dimming can be combined, as shown in Figure 22, thereby ensuring advantageous output current accuracy throughout the range from 100% rated current to very small currents.

Assume  $V_{REF\_any}$  represents any given REF voltage in the [A] region and  $I_o'$  represents  $I_o$  at that voltage. If  $I_o$  is  $I_o'$  or more, linear dimming is used. If  $I_o$  is  $I_o'$  or less, PWM dimming is used. The high level of the signal for PWM dimming is  $V_{REF\_any}$ , and the low level is  $V_{REF}$  in the oscillation off region. Combining the dimming methods enables adjustments to smaller currents than PWM dimming alone and achieves control with better output current accuracy than linear dimming alone.

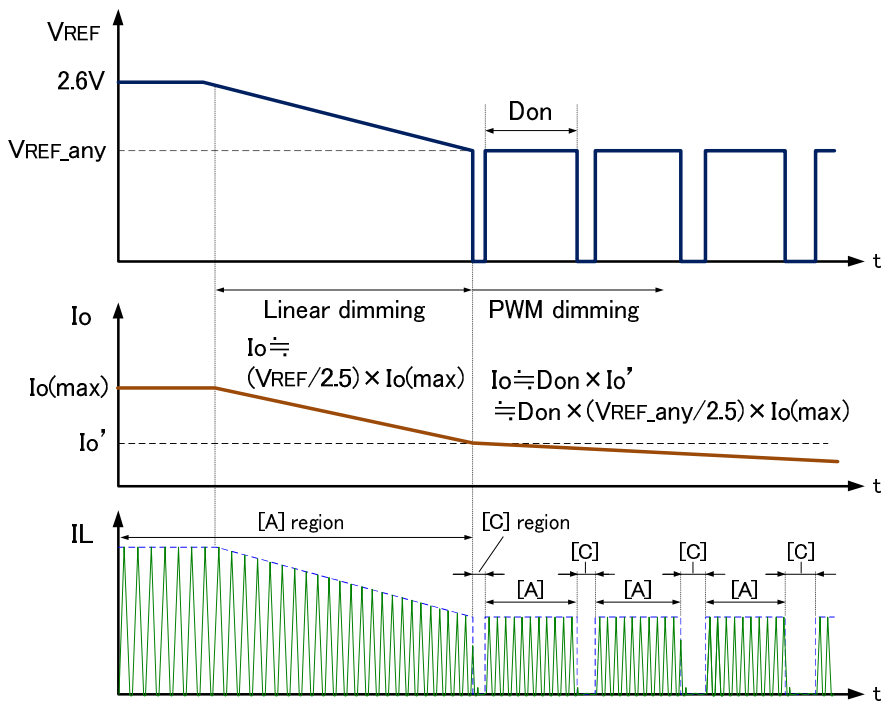

Figure 22 Combination of linear dimming and PWM dimming

## 5.3 Dimming circuit

### 5.3.1 Example of dimming circuit smoothing PWM signal

Figure 23 shows an example of a dimming circuit that smooths a PWM dimming signal and applies it to the REF pin. Assuming that  $V_{REF\_L}$  represents  $V_{REF}$  when the transistor Q101 is turned on and that  $V_{REF\_H}$  represents  $V_{REF}$  when the transistor is turned off in Figure 23, obtain the approximate values of those voltages using the formulas given below.

$$V_{REF\_H} = V_{DD} \times \frac{R102}{(R101 + R102)}$$

$$V_{REF\_L} = I_{ref} \times (R103 + R104)$$

Increasing  $V_{REF\_H}$  narrows the dimming range. Applying the formula above, set the value of resistors R101 + R102 with which the voltage becomes approximately 2.7 V. Make sure  $V_{DD}$  applied is stable. A widely changing  $V_{DD}$  will affect dimming accuracy.

To ensure that the IC operates in the oscillation off region when Q101 is turned on, set the value of resistors R103 + R104 with which  $V_{REF\_L}$ , even if varying, does not exceed 0.15 V.  $I_{ref}$  is the REF pin voltage pull-up current and it is 32  $\mu$ A (typical).

The components R103, R104, C101, and C102 smooth  $V_{REF\_H}$  and  $V_{REF\_L}$ , and  $V_{REF}$  obtained with the formula below is applied to the REF pin. Adjust the capacitance levels of C101 and C102 to 1  $\mu$ F or less while checking dimming characteristics.

$$V_{REF} = (1 - Don) \times V_{REF\_H} + Don \times V_{REF\_L}$$

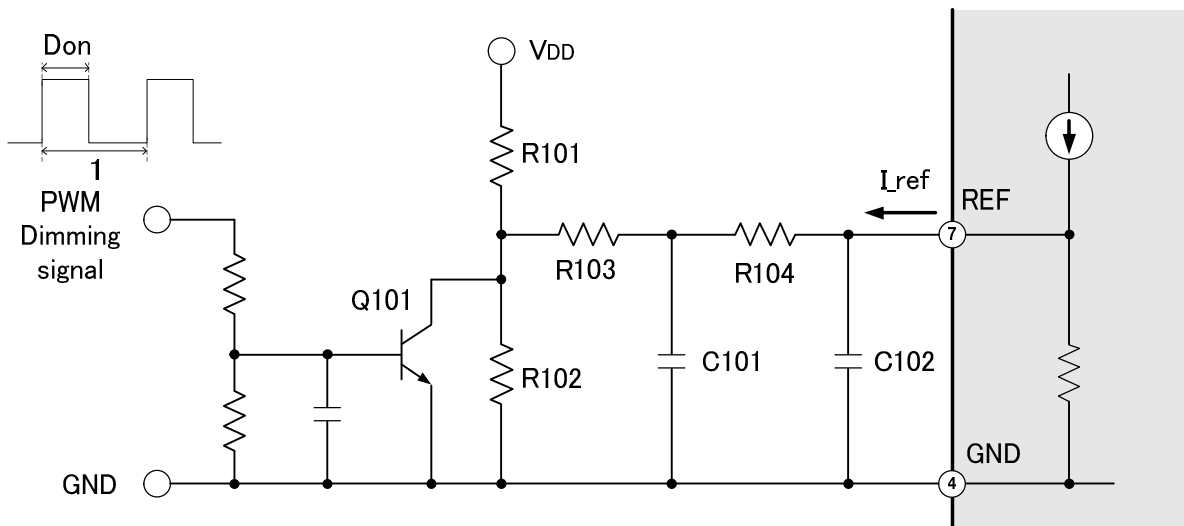

Figure 23 Example of PWM dimming signal smoothing circuit

## 6. Operations in abnormal situations

While the MV1012SC incorporates various protection functions, certain problems cannot be averted by the IC functions alone. Provided below are some examples of typical abnormal situations. These are provided as a guide.

Always perform appropriate testing using the actual apparatus, including open-circuit and short-circuit tests, to check operations in abnormal situations.

### 6.1 LED open-circuit

The MV1012SC has a latch-off function to protect against LED open-circuits using the auxiliary winding voltage and Vcc\_OVP function. For details, see [LED open-circuit protection using auxiliary winding] on page 16.

① Auxiliary winding is used:

⇒ The output voltage is detected indirectly using the auxiliary winding voltage, and the latch-off is performed with the Vcc\_OVP function.

② Auxiliary winding is not used:

⇒ The IC operates with the maximum on-time, Ton\_max. Vo becomes nearly equal to Vi.

The withstand voltage of the output capacitor should be the same as that of the input capacitor.

### 6.2 LED short-circuit

If Vo becomes 0 V, the operation automatically switches to the restart operation from zero current detection. That makes it possible to limit forcibly the current in the event of an LED short-circuit. After the short-circuit is resolved, the IC is automatically reset and starts to operate with zero current detection.

If the formula below is fulfilled, the IC operates in continuous conduction mode, and a short-circuit current flowing to the MOSFET or the fly-wheel diode is likely to increase. Make sure the actual apparatus is unaffected in such cases.

$$V_i > \frac{T_{off\_max}}{T_{on\_min}} \times V_F$$

$V_F$  is the forward voltage of the fly-wheel diode D1.

Figure 24 shows the ideal waveforms for the Svout and Svin pins in the event of an LED short-circuit. Make sure the Svin voltage always exceeds the Svout voltage in the event of an LED short-circuit. To prevent false switching-on due to noise, we recommend making the value of resistors R5 + R6 about 5% less than R7 + R8. For noise reduction, insert capacitors C8 and C9. (See Sections 3.2.10 and 3.2.13.)

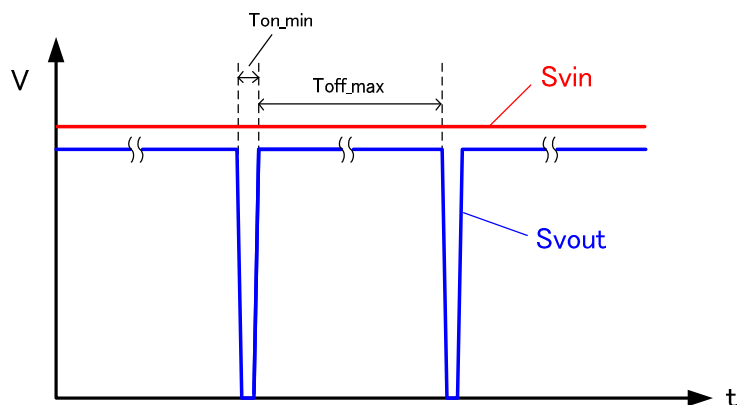

Figure 24 Svin and Svout pin waveforms in the event of an LED short-circuit

## 6.3 Abnormal heat buildup

The MV1012SC doesn't incorporate thermal shutdown. Install a separate protection circuit, if necessary.

## 6.4 CS pin open-circuit

If the CS pin open-circuit occurs,  $V_{cs}$  will increase due to the internal pull-up current and remain above the CS pin reference voltage. The IC will therefore operate with the minimum on-time  $T_{on\_min}$ , and  $I_o$  will decrease.

## 6.5 CS-GND short-circuit

The IC will be unable to perform peak current detection at the CS pin and will operate with the maximum on-time  $T_{on\_max}$ . As  $I_o$  increases, install a separate protection circuit, if necessary.

## 6.6 Current detection resistor open-circuit

The source of MOSFET will float, and MOSFET operations will become unstable. If the MOSFET switches off,  $I_o$  will approach zero. However, if the MOSFET is on, overvoltage will be applied to a CS pin, resulting in potential damage to the IC. Install a separate protection circuit, if necessary.

## 6.7 Current detection resistor short-circuit

$V_{cs}$  will become nearly equal to GND, and the IC will operate with the maximum on-time  $T_{on\_max}$ . As  $I_o$  increases, install a separate protection circuit, if necessary.

## 7. Standard circuit example

### 7.1 Power supply specification and circuit diagram

#### ◆ Power supply specification

	Min	Typ	Max	Unit
<b>Input voltage (DC)</b>	180		220	V
<b>Output voltage</b>	80	140	160	V
<b>Output current</b>	0.1(*)		300	mA
<b>Vcc voltage</b>		14		V

(\*) When  $V_{in} = 200\text{ V DC}$ ,  $V_o = 140\text{ V}$ ,  $V_{REF} = 0\text{ V}$

#### ◆ Circuit diagram

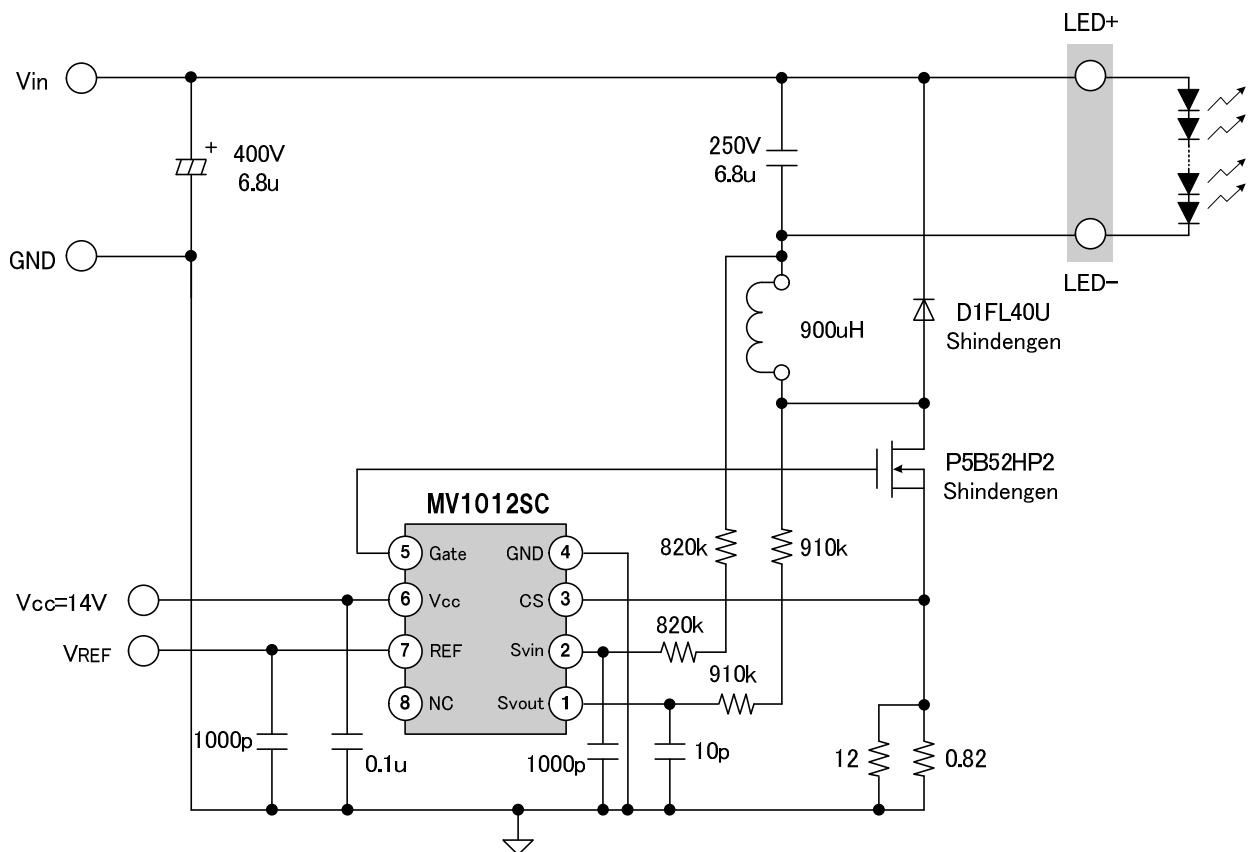

## 7.2 Power supply characteristics

◆ Efficiency characteristics  
( $V_{in} = 200\text{ V DC}$ ,  $V_{cc} = 14\text{ V}$ )

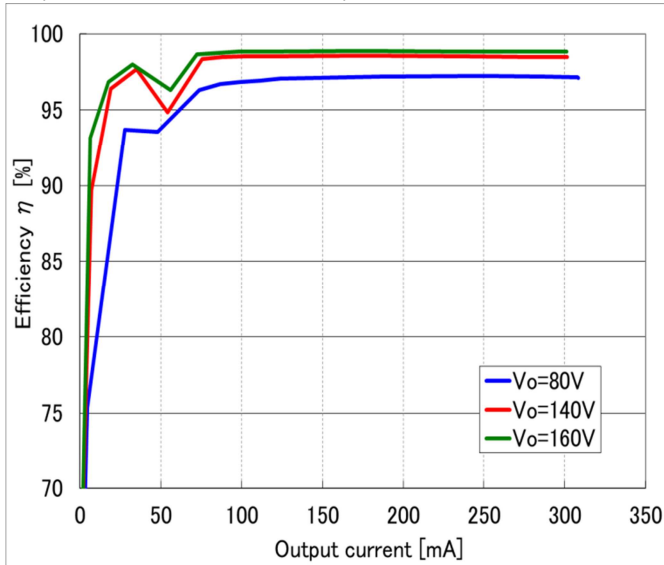

◆ Dimming characteristics  
( $V_{in} = 200\text{ V DC}$ ,  $V_o = 140\text{ V}$ ,  $V_{cc} = 14\text{ V}$ )

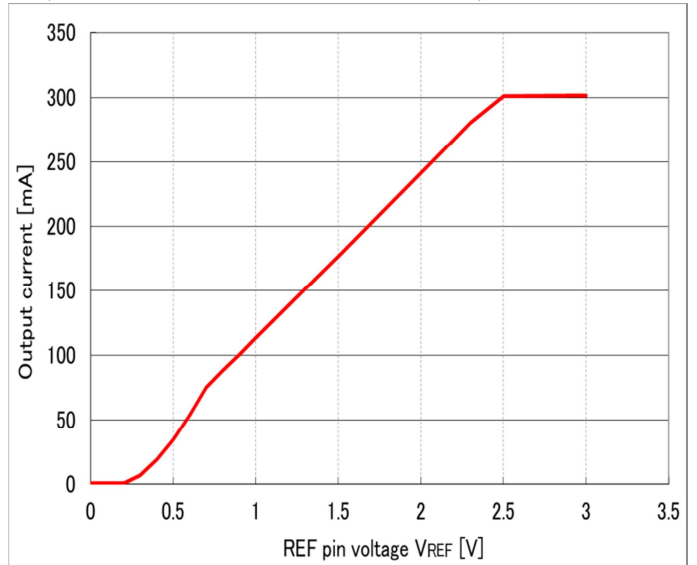

## 7.3 Example of operation waveform

Waveform in the [A] frequency modulation region

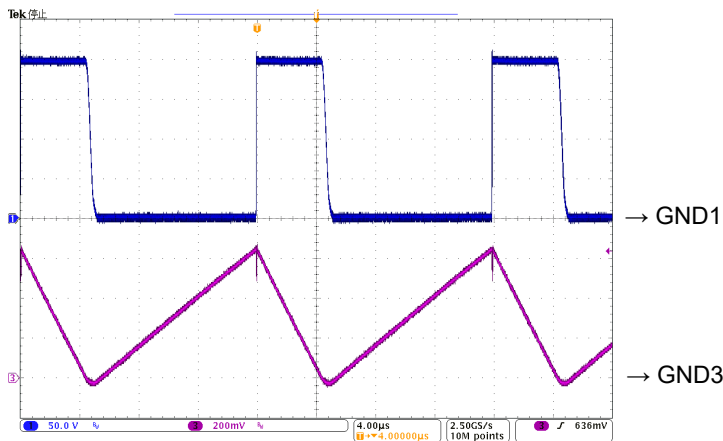

CH1	$V_{ds}$	50 V/div
CH3	$I_L$	0.2 A/div
time		4 $\mu\text{s}/\text{div}$
$V_{in}$		200 V DC
$I_o$		300 mA
Dimming ratio of 100%		
$V_o = 140\text{ V}$		

Waveform in the [B] off-time modulation region

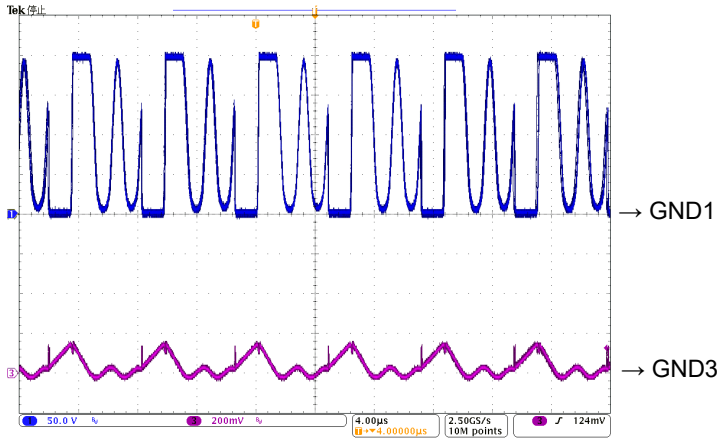

CH1	V <sub>DS</sub>	50 V/div
CH3	I <sub>L</sub>	0.2 A/div
time	4 us/div	
V <sub>in</sub>	200 V DC	
I <sub>o</sub>	30 mA	
Dimming ratio of 10%		
V <sub>o</sub> = 140 V		

Waveform in the [C] oscillation off region

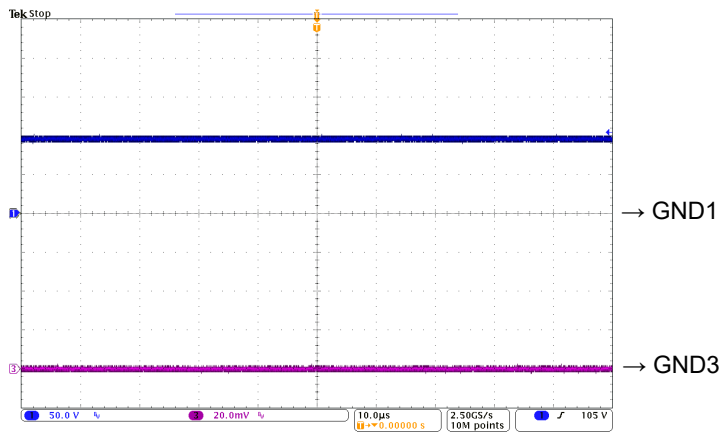

CH1	V <sub>DS</sub>	50 V/div
CH3	I <sub>L</sub>	0.2 A/div
time	10 us/div	
V <sub>in</sub>	200 V DC	
I <sub>o</sub>	0.1 mA	
oscillation off		
V <sub>o</sub> = 140 V		



