

SH1LC1140, SH1LF1140 PERMANENT MAGNET SOLENOID

UNIT: $\frac{\text{mm}}{\text{(inch)}}$
 SHOWN ENERGIZED

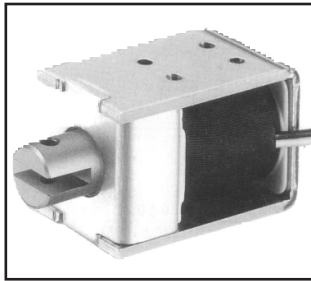

WEIGHT : 120g
 PLUNGER : 28g

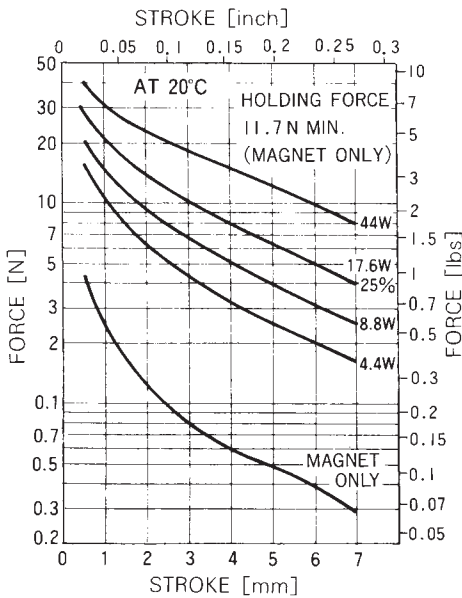
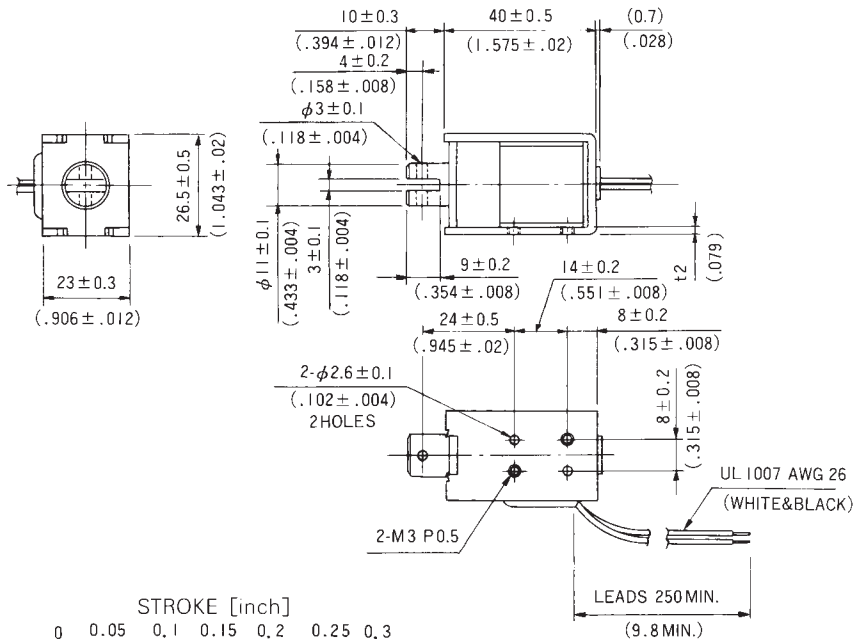

STROKE - FORCE

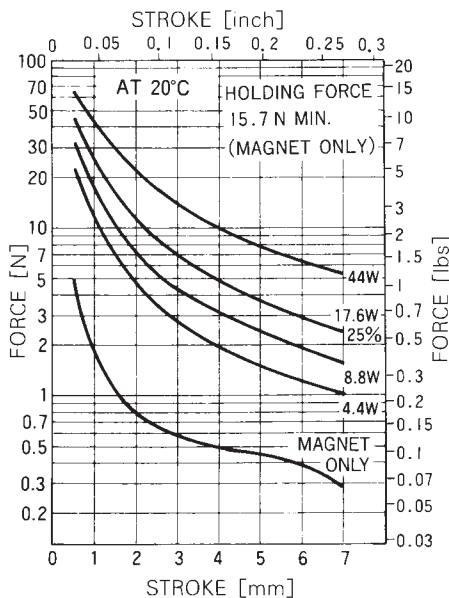

STROKE - FORCE

DRIVE CIRCUITS

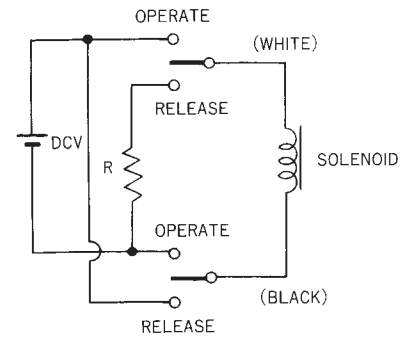

COIL DATA

	without heat sink			release current (reference)
	duty cycle = $\frac{\text{"on" time}}{\text{"on" time} + \text{"off" time}} \times 100\%$		25% or less	
	maximum "on" time in seconds		20	
	watts at 20°C	17.6		
	ampere-turns at 20°C		968	
type no.	resistance $\Omega \pm 10\%$ (at 20°C)	no. turns	volts DC	ampere
SH1LC1140-06 SH1LF1140-06	2.1	340	6	1,060mA
SH1LC1140-12 SH1LF1140-12	8.2	640	12	560mA
SH1LC1140-24 SH1LF1140-24	32.7	1,360	24	260mA

Shindengen

America, Inc.

1 - 800 - 543 - 6525