

SIZE130A PULL TUBULAR SOLENOID

UNIT: $\frac{\text{mm}}{\text{(inch)}}$

SHOWN ENERGIZED

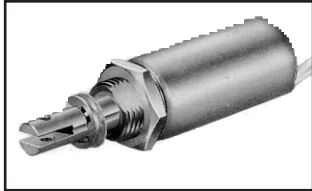

WEIGHT : 24g
PLUNGER : 5g

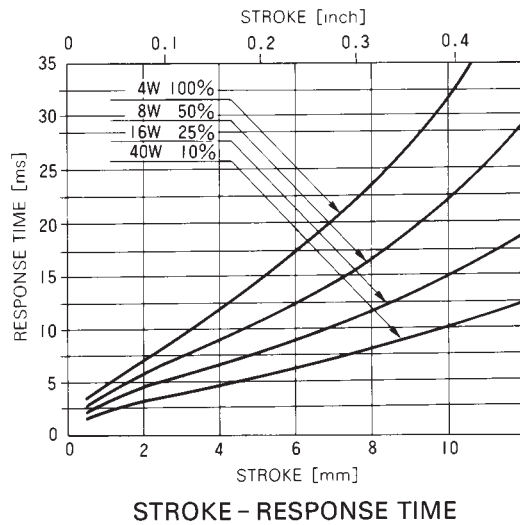
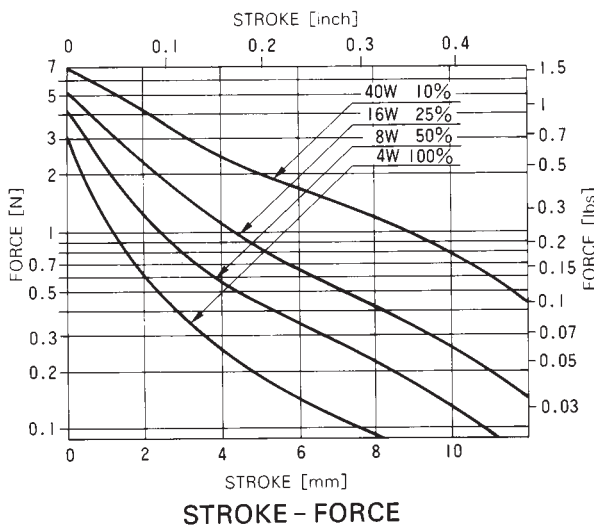
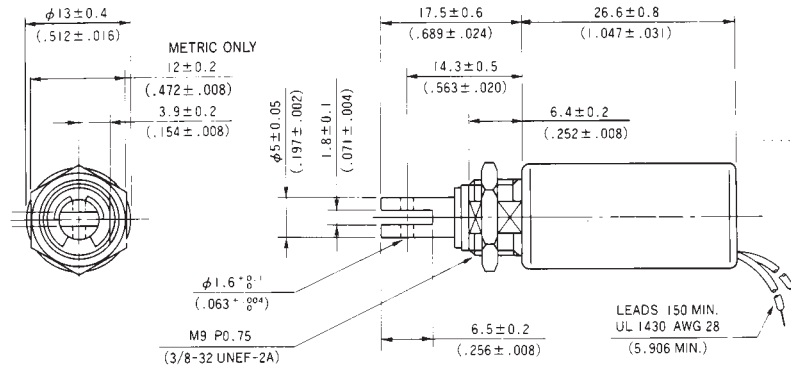

COIL DATA

Heat sink : 50×50×3mm aluminum

duty cycle = $\frac{\text{"on" time}}{\text{"on" time} + \text{"off" time}} \times 100\%$			100% continuous	50% or less	25% or less	10% or less
MAX. "on" time in seconds			∞	50	5	2
watts at 20°C			4	8	16	40
ampere-turns at 20°C			453	640	905	1440
AWG no.	resistance $\Omega \pm 10\%$ (at 20°C)	no. turns	volts DC			
29	2.68	372	3.3	4.5	6.5	10.4
30	3.94	426	4.2	5.9	8.4	13.3
31	7.36	632	5.3	7.4	10.5	16.8
32	10.1	704	6.5	9.2	13	21
33	18.1	990	8.3	11.7	16.5	26
34	25.6	1100	10.6	14.9	21	34
35	44.2	1500	13.6	19.2	27	43
36	71.3	1932	16.9	24	34	54
37	99	2170	21	29	41	66
38	159.5	2768	26	37	52	83
39	300	3980	34	48	68	109
40	469	4884	44	61	87	138
41	709	6024	53	75	107	170
42	1152	7784	67	95	134	213
43	1780	9330	87	112	173	275

Shindengen America, Inc.