

# SIZE110A PULL TUBULAR SOLENOID

UNIT:  $\frac{\text{mm}}{\text{(inch)}}$

SHOWN ENERGIZED



WEIGHT : 19g  
PLUNGER : 4g

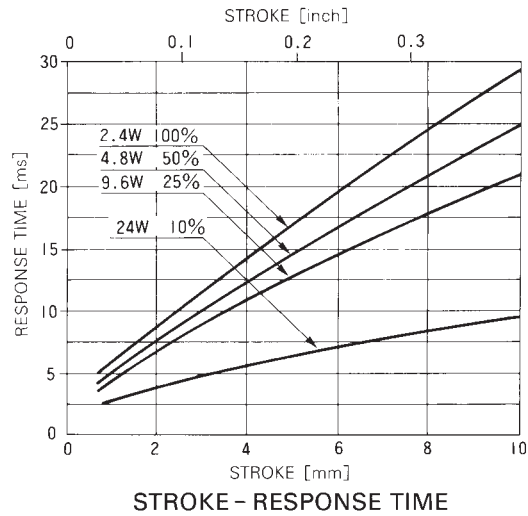
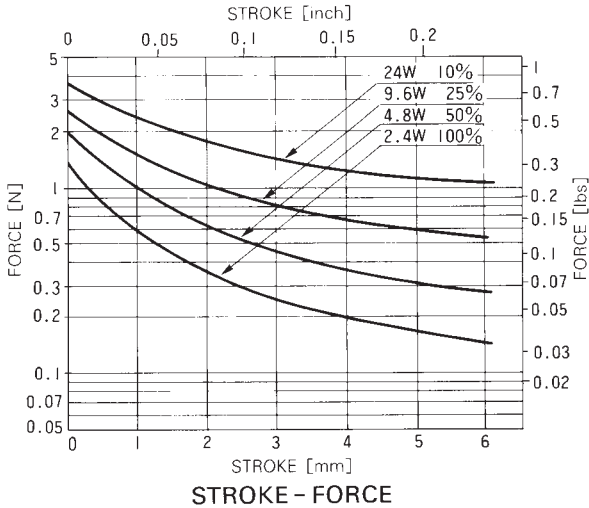
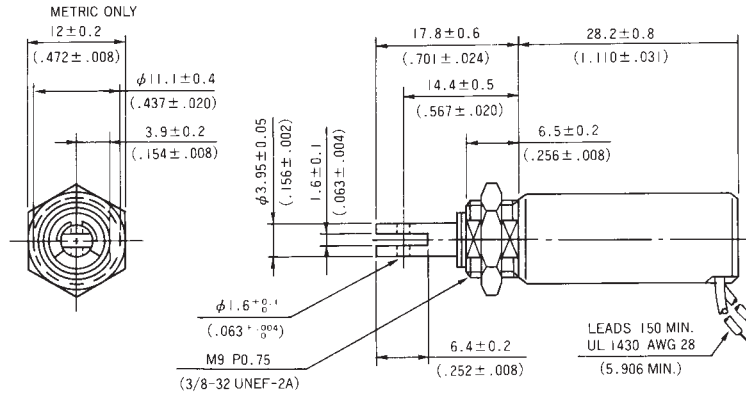

## COIL DATA

Heat sink : 50×50×3mm aluminum

duty cycle = $\frac{\text{"on" time}}{\text{"on" time} + \text{"off" time}} \times 100\%$			100% continuous	50% or less	25% or less	10% or less
MAX. "on" time in seconds			∞	35	4	2
watts at 20°C			2.4	4.8	9.6	24
ampere-turns at 20°C			400	568	800	1265
AWG no.	resistance Ω ± 10% (at 20°C)	no. turns	volts DC			
28	1.84	356	2.1	2.9	4.1	6.5
29	2.58	405	2.5	3.6	5.1	8.1
30	4.71	580	3.3	4.6	6.5	10.3
31	6.62	680	4	5.5	7.8	12.3
32	11.5	890	5.2	7.3	10.4	16.4
33	16.4	1050	6.2	8.8	12.5	19.7
34	26.7	1370	7.9	11	15.6	25
35	45.4	1780	10.3	14.4	20	32
36	63	2020	12.3	17.6	25	39
37	94	2460	15	22	31	48
38	159	3400	19.3	27	38	59
39	287	4600	26	35	50	79
40	399	5130	31	44	62	99

Shindengen America, Inc.