

SIZE250 PULL, 250 PUSH TUBULAR SOLENOID

UNIT: $\frac{\text{mm}}{\text{(inch)}}$

SHOWN ENERGIZED

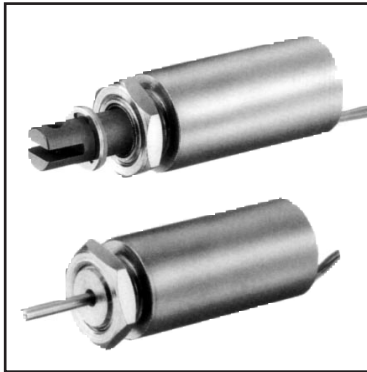

PULL

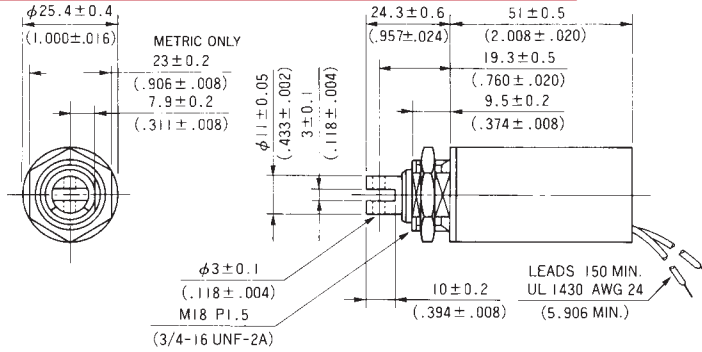

PUSH

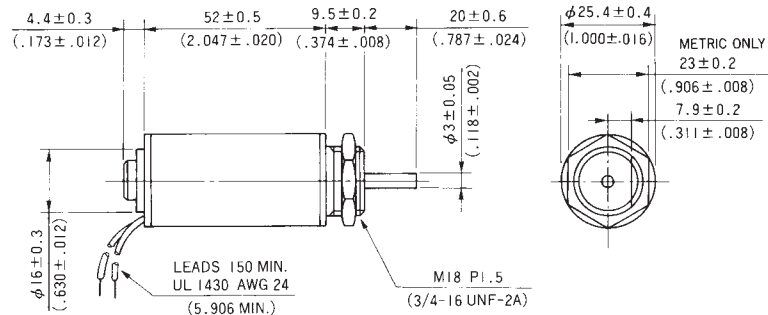

WEIGHT : 188g
PLUNGER
PULL : 44g
PUSH : 35g

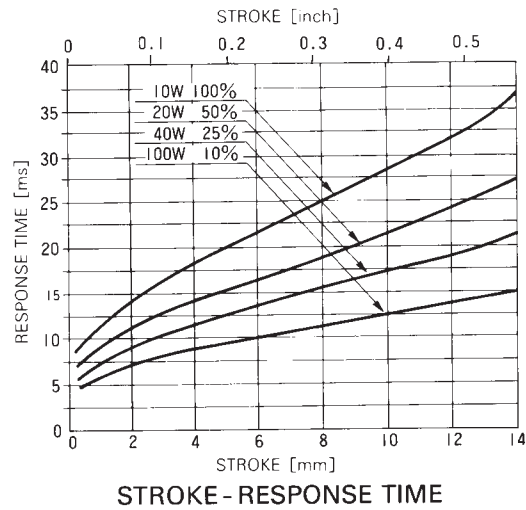
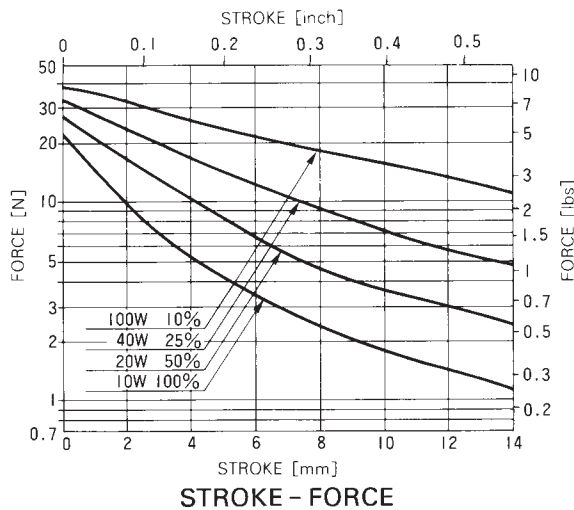

COIL DATA

Heat sink : 100×100×3mm aluminum

duty cycle = $\frac{\text{"on" time}}{\text{"on" time} + \text{"off" time}} \times 100\%$			100% continuous	50% or less	25% or less	10% or less
MAX. "on" time in seconds			∞	360	32	8
watts at 20°C			10	20	40	100
ampere-turns at 20°C			1090	1541	2180	3447
AWG. no.	resistance $\Omega \pm 10\%$ (at 20°C)	no. turns	volts DC			
23	1.49	402	4.1	5.8	8.2	13
24	2.87	600	5.2	7.4	10.4	16.4
25	3.98	672	6.6	9.3	13.1	21
26	7.06	940	8.3	11.7	16.6	26
27	9.83	1050	10.4	14.6	21	33
28	16.9	1415	13.2	18.6	26	42
29	27.0	1820	16.4	23	33	52
30	45.0	2365	21	30	42	66
31	71.6	2990	26	37	53	84
32	107	3660	32	46	65	102
33	172	4550	42	59	83	132
34	265	5550	53	75	106	167
35	443	7310	67	95	134	212
36	658	8660	84	119	168	265
37	1032	11000	104	147	207	328
38	1535	12930	131	185	262	415

1 - 800 - 543 - 6525