

SIZE700 ROTARY SOLENOID

UNIT: $\frac{\text{mm}}{\text{(inch)}}$

SHOWN DE-ENERGIZED, RIGHT HAND ROTATION



WEIGHT (ABD&R) : 1,013g

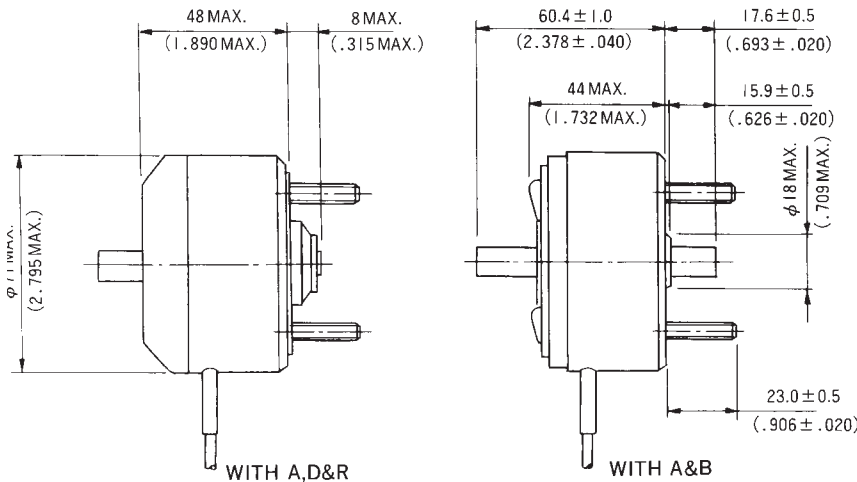
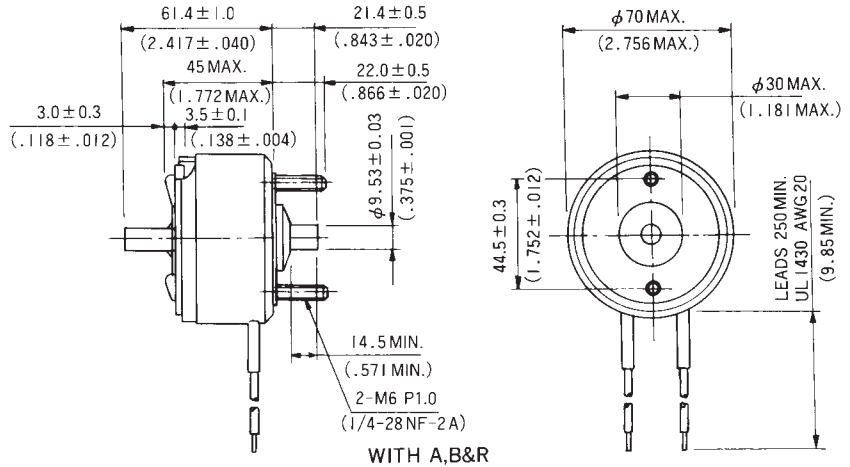

$\frac{1}{2}$ ROTATION ANGLE $\pm 3^\circ$ TO LEFT OF CENTER FOR R.H. ROTATION, RIGHT OF CENTER FOR L.H. ROTATION.

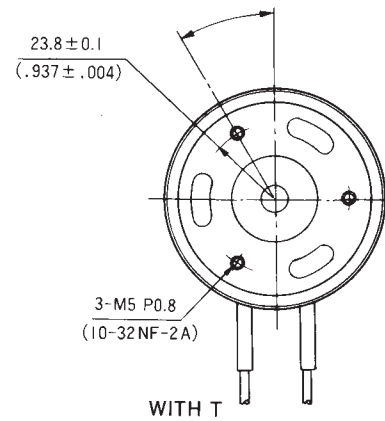

COIL DATA

Heat sink : 390×390×3mm aluminum

Return spring torque : 0.075~0.105 N·m

duty cycle = $\frac{\text{"on" time}}{\text{"on" time} + \text{"off" time}} \times 100\%$			100% continuous	75% or less	50% or less	25% or less	10% or less	
MAX. "on" time in seconds			∞	112	80	37	16	
watts at 20°C			35	46.5	70	140	350	
ampere-turns at 20°C			1570	1800	2230	3150	5000	
gross starting torque at 20°C (N·m)			25°	1.27	2.12	3.8	4.9	
			35°	0.69	0.99	2.53	4.37	
			45°	0.58	0.78	1.0	1.88	3.42
			67.5°	0.288	0.355	0.59	1.12	2.01
			95°	0.178	0.3	0.4	0.735	1.21
AWG no.	resistance $\Omega \pm 10\%$ (at 20°C)	no. turns	volts DC					
20	1.88	368	8	9.3	11	16	26	
21	3.01	468	10	11	14	20	32	
22	4.82	580	13	15	18	26	41	
23	8.1	780	16	19	23	33	52	
24	12.3	949	20	23	29	41	65	
25	19	1148	26	30	37	52	83	
26	30.8	1472	33	38	46	66	105	
27	48.8	1854	41	47	59	83	132	
28	81.1	2436	52	60	75	105	166	
29	121	2944	64	74	92	130	206	
30	190	3650	82	94	118	166	264	
31	275	4175	104	119	147	209	331	
32	440	5792	119	137	170	240	—	
33	735	7000	165	191	235	331	—	
34	995	7600	204	239	288	—	—	

1 - 800 - 543 - 6525